

# THE COLLECTION

by Michael Miller

## Parada Illumia L

**HIGH EFFICIENCY INSET ROOM HEATER**

**Installation, Maintenance & User Instructions**

**Hand these instructions to the user**

**Model No's DHVG\*\*RN2 is for use on Natural Gas (G20) at a supply pressure of 20 mbar in G.B. / I.E.**

**\*\* Denotes trim & colour variant**

## **Information Requirements for Commission Regulation (EU) 2015/1188**

<b>Model Identifier</b>	<b>DHVG**RN2</b>
<b>Indirect Heating Functionality</b>	<b>No</b>
<b>Direct Heat Output</b>	<b>5.2kW</b>
<b>Indirect Heat Output</b>	<b>Not Applicable</b>
<b>Fuel</b>	<b>Natural Gas (G20)</b>
<b>NOx Emissions</b>	<b>130mg/kWh</b>
<b>Nominal Heat Output</b>	<b>5.2kW</b>
<b>Minimum Heat Output (Indicative)</b>	<b>1.0kW</b>
<b>Useful Efficiency at Nominal Heat Output</b>	<b>83.0%</b>
<b>Useful Efficiency at Minimum Heat Output (Indicative)</b>	<b>50.0%</b>
<b>Auxilliary Power Consumption at Nominal Heat Output</b>	<b>0.09kW</b>
<b>Auxilliary Power Consumption at Minimum Output</b>	<b>0.09kW</b>
<b>Auxilliary Power Consumption at Standby Mode</b>	<b>0.01kW</b>
<b>Permanent Pilot Flame Requirement</b>	<b>0.25kW</b>
<b>Type of Heat Output / Room Temperature Control</b>	<b>With electronic room temperature control plus day timer</b>
<b>Contact Details</b>	<b>BFM Europe Ltd. Gordon Banks Drive Trentham Lakes North Stoke-on-Trent ST4 4TJ Tel : 01782 339000</b>

<b>Section 1</b>	<b>Information and Requirements</b>	<b>PAGE</b>
1.0	Appliance Information	3
1.1	Conditions of Installation	4
1.2	Flue and chimney suitability	4
1.3	Fireplace / surround suitability	5
1.4	Shelf position	5
1.5	Chimney inspection	5
1.6	Fire place opening / catchment space	6-7
1.7	Chair bricks	7
1.8	Metal flue boxes	7
1.9	Spillage monitoring system	8
<b>Section 2</b>	<b>Installation of Fire</b>	
2.1	Unpacking the fire	9
2.2	Installing the fire box	10-11
2.3	Securing the combustion chamber to the opening	12
2.4	Removing the burner assembly	13
2.5	Installing the gas supply	14
2.6	Making the electrical connection	15
2.7	Gas tightness and inlet pressure	15
2.5	Installation of lamp assemblies	16-17
2.6	Installation of Parada surround	18
<b>Section 3</b>	<b>Assembling Fuel Bed and Commissioning</b>	
3.1	Fitting the log fuelbed	19-23
3.2	Fitting the fuel-bed pebble set	24
3.3	Lighting the appliance	25-31
3.3.9	Fitting the handset wall bracket / dimmer light bulbs	31
3.3.10	Instructing the user / product handover	32
3.4	Removal / re-fitting the restrictor baffle	32
3.5	Fitting the handset wall bracket	32
3.6	Checking for clearance of combustion products	33
<b>Section 4</b>	<b>Maintenance</b>	
4.1	Removal of the burner assembly	34
4.2	Removal of the control valve	34
4.3	Removal of the oxypilot	35
4.4	Removal of the receiver unit	35
4.5	Removal of the convection fan	35
4.6	Replacing the battery in the handset	35
4.7	Access and checking the flue debris void	36
4.8	Spare parts shortlist	36
4.9	Wiring diagram	37
<b>Section 5</b>	<b>User Instructions Section</b>	
5.1	Conditions of installation	38
5.2	About your new fire	39
5.3	Operating the fire	40-45
5.4	Cleaning instructions	46
5.5	Removal / re-fitting the glass frame assembly	47-48
5.6	Removal / replacement of the log fuelbed	49-53
5.7	Removal / replacement of the pebble fuelbed	54
5.8	User replaceable parts	55

This appliance is manufactured by :- BFM Europe Ltd, Trentham Lakes, Stoke-on-Trent, ST4 4TJ.

# SECTION 1 INFORMATION AND REQUIREMENTS

## 1.0 APPLIANCE INFORMATION

Main injector : (1 off)	Stereomatic Cat 82 – size 2.05 (NG)
Pilot Type :	NG - Seagas P5-29D
Max. Gross Heat Input :	6.9 kW
Min. Gross Heat Input :	2.0 kW
Cold Inlet Pressure :	G20 20.0+/-1.0 mbar (8.0 +/- 0.4 in w.g.)
Ignition :	Integral to gas valve
Electrode Spark Gap :	4.0mm
Packed Weight Combustion Chamber :	58kg
Gas Connection :	8mm compression (supplied with fire)
Supply Voltage :	230V a.c.
Supply Frequency :	50Hz
Supply Fuse :	3 Amp to BS 1362
Electrical Supply Required	230v AC, 50Hz
IP Rating	IPX0

**Fig. 1**

**Top View of Combustion Chamber**

**Side View of Combustion Chamber**

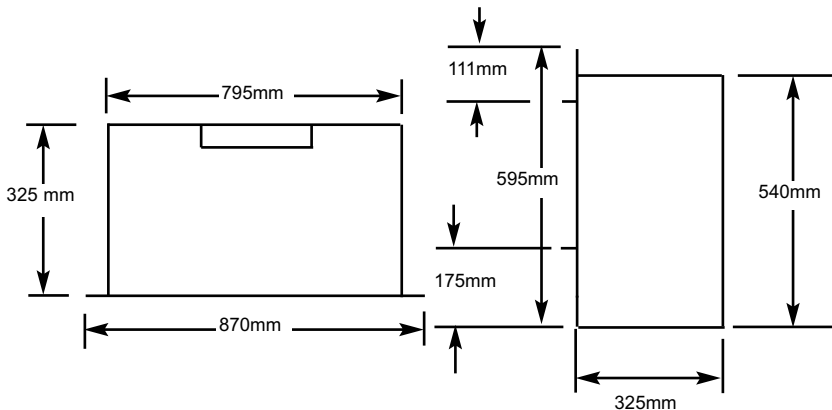

# INSTALLATION REQUIREMENTS

## 1.1 CONDITIONS OF INSTALLATION

It is the law that all gas appliances are installed only by a GAS SAFE Registered Installer, in accordance with these installation instructions and the Gas Safety (Installation and Use) Regulations 1998 as amended. Failure to install appliances correctly could lead to prosecution. It is in your own interest and that of safety to comply with the law. The installation must also be in accordance with all relevant parts of the Local and National Building Regulations where appropriate, the Building Regulations (Scotland Consolidation) issued by the Scottish Development Department, and all applicable requirements of the following British Standard Code of Practice.

1. BS 5871 Part 2 Installation of Inset Live Fuel Effect Gas Fires
2. BS 6891 Installation of Gas Pipework
3. BS 5440 Parts 1 & 2 Installation of Flues and Ventilation
4. BS 1251 Open fire place components
5. BS 715 / BS EN 1856-2 Metal flue pipes for gas appliances
6. BS EN 1858 Clay Flue Blocks and Terminals
7. IS 813 : Domestic Gas Installation (Republic of Ireland)

**No purpose made additional ventilation is normally required for this appliance, when installed in G.B. When installing in I.E. please consult document I.S. 813 : Domestic Gas Installation, which is issued by the National Standards Authority of Ireland. If installing in Northern Ireland, please consult local building regulations. Any purpose made ventilation must be checked periodically to ensure that it is free from obstruction.**

## 1.2 FLUE AND CHIMNEY SUITABILITY

This appliance is designed for use with conventional brick built or lined chimneys and fabricated flues and metal flue boxes conforming to BS 715 / BS EN 1856-2. All flues must conform to the following minimum dimensions.

<b>Minimum diameter of circular flues</b>	<b>125 mm</b>
<b>Minimum effective height of all flue types</b>	<b>4 metres</b>

Safe clearance of products must always be checked by carrying out a smoke match test as described in section 3.6

### 1.3 FIREPLACE / SURROUND SUITABILITY

The fire must only be installed with a hearth it **must not be installed directly onto carpet or other combustible floor materials.**

**This product can only be installed with surround designs available from BFM Europe Ltd or designs which meet the criteria as required by BFM Fires. For further details of specification requirements please contact BFM Europe Technical Service.**

### 1.4 SHELF POSITION

The fire may be fitted below a combustible shelf providing there is a minimum distance of 200mm above the top of the fire and the shelf does not project more than 150mm. If the shelf overhangs more than 150mm the distance between the fire and the shelf must be increased by 15mm for every 25mm of additional overhang over 150mm.

### 1.5 FLUE / CHIMNEY INSPECTION

Before commencing installation, a flue or chimney should be inspected to ensure that all the following conditions are satisfied.

1. Check that the chimney / flue only serves one fire place and is clear of any obstruction. Any dampers or register plates must be removed or locked in the open position.
2. Brick/stone built chimneys or any chimney or flue which has been used for an appliance burning fuel other than gas must be thoroughly swept. The base of the chimney / flue must also be thoroughly cleared of debris etc.
3. Any under-floor air supply to the fire place must be completely sealed off.
4. Ensure that the inside of the chimney / flue is in good condition along its length and check that there is no leakage of smoke through the structure of the chimney during and after the smoke pellet test.
5. **Using a smoke pellet, check that there is an up-draught in the chimney / flue and that the smoke can be seen issuing from the terminal / chimney pot outside. There must be no leakage of smoke through the structure of the chimney during or after the smoke pellet test and it is important to check inside upstairs rooms adjacent to the chimney / flue.** Check the chimney pot / terminal and general condition of the brickwork or masonry. If the chimney or flue is in poor condition or if there is no up-draught do not proceed with the installation. If there is a history of down-draught conditions with the chimney / flue, a tested and

certificated flue terminal or cowl suitable for the relevant flue type should be considered.

6. **A spillage test must always be carried out during commissioning of the appliance.**

### 1.6 FIRE PLACE OPENING AND CHIMNEY CATCHMENT SPACE

The front opening of the fire place must be between 830mm and 840mm wide, and between 560mm and 570mm high. If the opening exceeds these dimensions then a surround must be constructed from suitable non-combustible material to produce a correct size opening. Any surround must be suitably sealed to the fire place to prevent leakage. See below in figure 2.

**NOTE :** Opening height must be measured from top face of hearth panel when installed not from floor level. Height of Collection hearth is 60mm

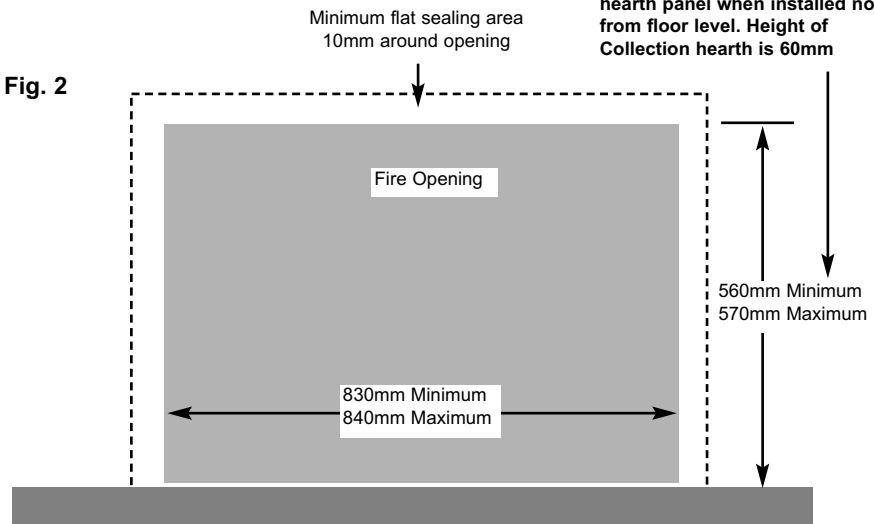

When installing into a brick built chimney, you must ensure that there is sufficient depth to accommodate any debris which may fall from the chimney. This depth must be sufficient to accommodate 12 litres of volumetric space in a conventional brick built chimney.

**Table A - Installation Depth Requirements for The Collection Parada L being installed into a brick built chimney, requiring 12.0 litres of debris collection volume (figure 3).**

Fig. 3

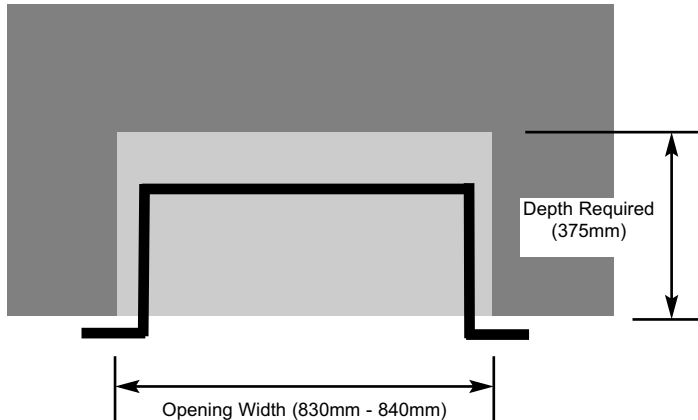

**1.7 FITTING TO FIREPLACES WITH EXISTING CHAIRBRICKS AND CONVENTIONAL BRICKBUILT CHIMNEYS**

This appliance is not suitable for use in fireplaces fitted with an existing chairbrick without the removal of the chairbrick.

**1.8 FITTING TO PRE-FABRICATED TWIN WALL METAL FLUE BOXES**

A purpose designed flue box is available for this product direct from the manufacturer. Please quote part number 1161-169030. **If the flue requires lining, an optional extra flue connection plate assembly can be ordered to assist with the flue connection. This assembly can be obtained from your local stockist, please quote part number 1130-127120. Included with this assembly are fitting instructions.**

**1.9 SPILLAGE MONITORING SYSTEM**

This appliance is fitted with an atmosphere sensing spillage monitoring system in the form of an oxygen sensing burner. This is designed to shut the fire off in the event of a partial or complete blockage of the flue causing a build up of combustion products in the room in which the fire is operated. **The following are important warnings relating to this spillage monitoring system :-**

- 1.9.1 The spillage monitoring system must not be adjusted by the installer.
- 1.9.2 The spillage monitoring system must not be put out of operation.
- 1.9.3 When the spillage monitoring system is exchanged only a complete original manufacturers part may be fitted.



## SECTION 2 INSTALLATION OF FIRE

### 2.1 UNPACKING THE FIRE

Carefully lift the combustion chamber out of the carton. Remove the loose item packaging carefully from the pack. Check the contents as listed :-

**DO NOT UNDER ANY CIRCUMSTANCES USE THIS APPLIANCE IF THE GLASS PANEL IS BROKEN OR NOT SECURELY FIXED TO THE FIREBOX.**

Packing Check List - All Models

#### Pack 1 of 2 - Combustion Chamber Pack

- |       |   |  |
|-------|---|--|
| 1 off | Combustion Chamber & Glass Assembly                           |  |
| 1 off | Boxed ceramic fuel-bed set (packed inside combustion chamber) |  |
| 1 off | Installation instruction / user manual                        |  |
| 1 off | Thermostatic remote handset                                   |  |
| 1 off | Loose items pack containing :-                                | 3 off AAA batteries, remote handset, 1 off handset wall brkt (inc. fixings), 1 off glass removal tool, 1 off downlight kit, 4 off 8mm rawlplugs and screws, 2 off surround leg securing brackets, 1 off efficiency baffle & fixing screws. |

#### Pack 2 of 2 - Surround (see figure 4 below)

- |       |                |                        |
|-------|----------------|------------------------|
| 1 off | Hearth panel   | 1 off shelf infill     |
| 1 off | Shelf          | 2 off legs (R/H & L/H) |
| 1 off | Bottom section | 2 off side infills     |
| 1 off | Top infill     |                        |

**Fig. 4**

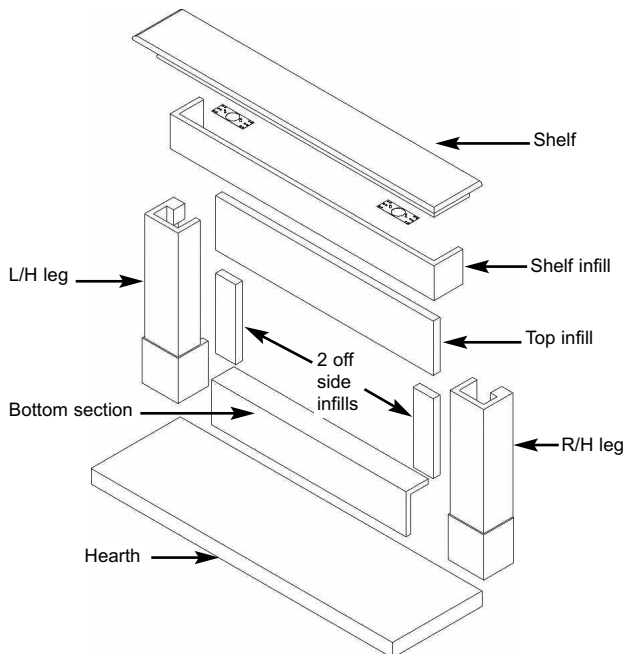

## 2.2 INSTALLING THE FIREBOX

- 2.2.1 Remove both the side trims which are held in place by the magnets then remove the grill panel securing screws as below in figure 5.

Fig. 5

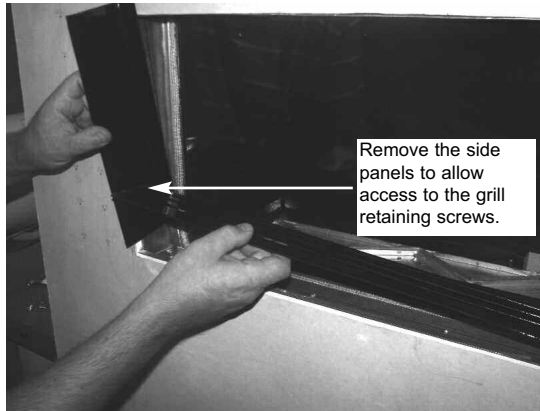

- 2.2.2 Secure the glass clamp to the glass panel as shown below in figure 6, to remove the glass panel lift vertically then pull forwards. See figure 7 overpage which shows how the glass frame is located on the top of the combustion chamber.

Fig. 6

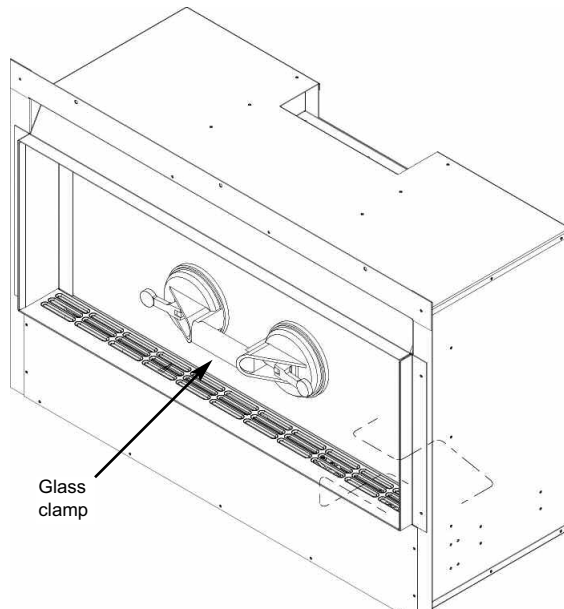

- 2.2.3 Remove the 5 off securing screws and glass panel retaining bracket that are located on the top underside face of the combustion chamber behind the canopy. See figure 7 below.

**Fig. 7**

Glass Panel Retaining Bracket, secured by 5 off screws

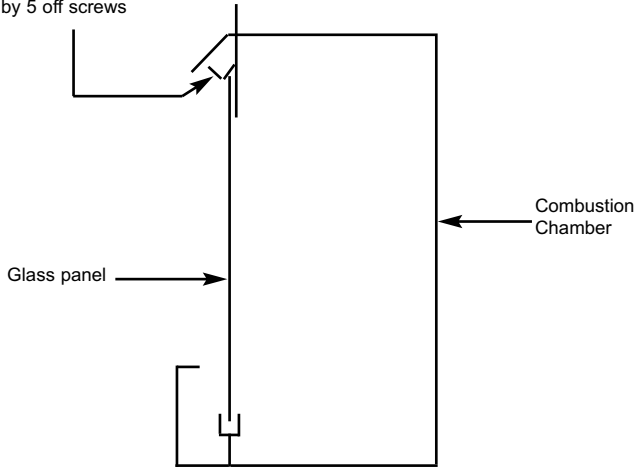

- 2.2.4 Lift the glass panel vertically to release from the bottom retaining channel and then tilt forwards as shown below in figure 8 & 9 to release.

**Fig. 8**

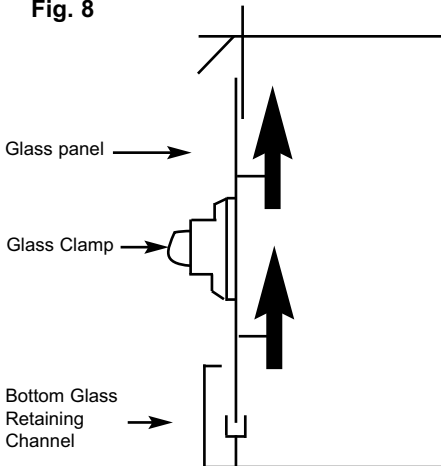

**Fig. 9**

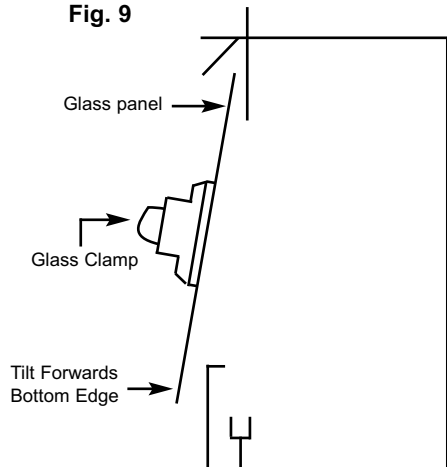

2.2.5 Store the glass frame assembly in a safe place.

2.2.6 Re-assemble in reverse order when re-fitting the glass assembly.

**Ensure that the glass assembly is correctly located on the top flange of the combustion chamber, this can be achieved by putting your hand onto the top edge of the glass frame inside the convection air aperture and pushing down firmly to check the glass frame is correctly located.**

**DO NOT OPERATE THE FIRE WITHOUT THE GLASS FRAME ASSEMBLY IN POSITION OR NOT CORRECTLY LOCATED.**

## 2.3 SECURING THE COMBUSTION CHAMBER TO THE OPENING

2.3.1 The combustion chamber must be secured to the opening via the four off screw and rawlplugs provided. Figure 10 below shows the hole centres in the mounting flanges of the combustion chamber.

Fig. 10

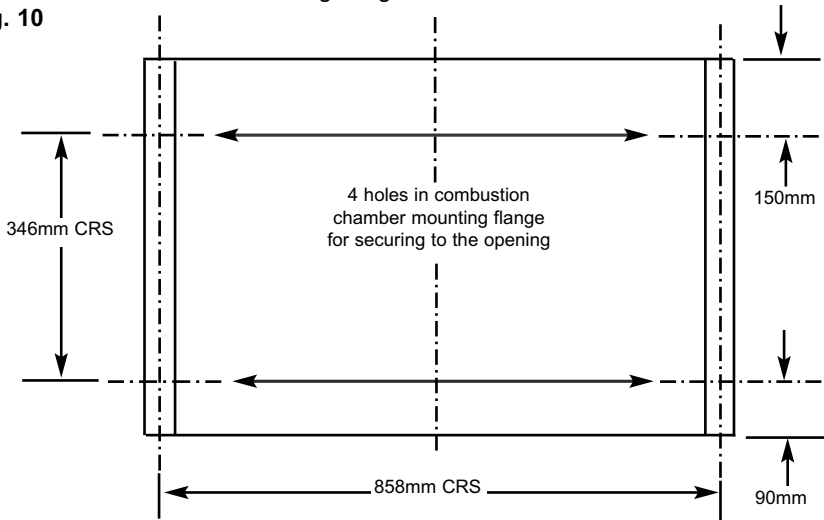

2.3.2 DO NOT SECURE THE COMBUSTION CHAMBER INTO THE OPENING AT THIS POINT AS ACCESS WILL STILL BE REQUIRED TO RUN THE GAS SUPPLY PIPEWORK AS DETAILED IN SECTION 2.5

Fig. 11

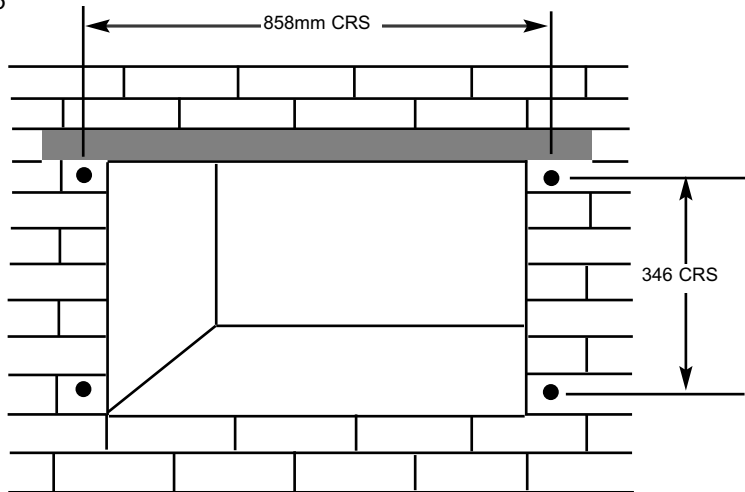

## 2.4 REMOVING THE BURNER ASSEMBLY

- 2.4.1 Lift the burner tray cover vertically clear as shown below in figure 12 and store in a safe place.

**Fig. 12**

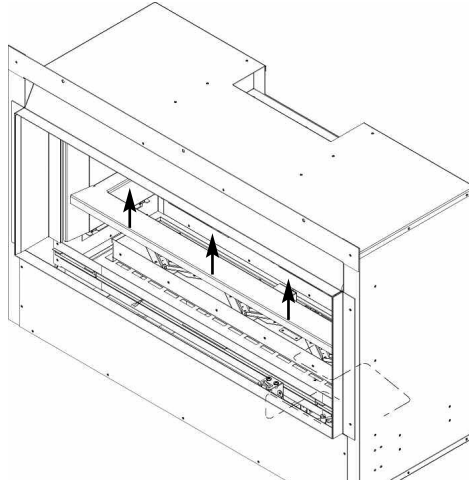

- 2.4.2 This will allow access to the 8 off burner retaining screws, 4 off at the rear of the burner and 2 off at each side as shown below in figure 13. With the 8 off burner screws removed, lift the burner unit until the controls are clear then remove in a forward direction.

**Fig. 13**

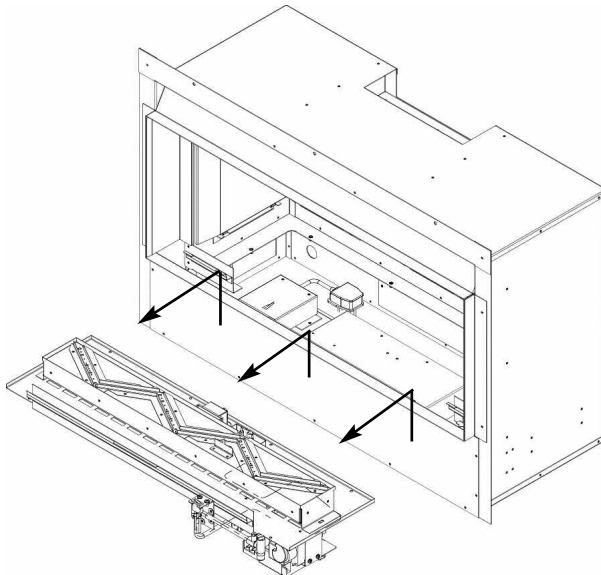

## 2.5 INSTALLATION OF THE GAS SUPPLY

- 2.5.1 Before installing the combustion chamber, decide from which side or if a rear connection to the gas supply is required. Plan the pipe run to enter from the rear or below the firebox from the left, right or rear and connect to the inlet elbow. See figure 14, 15 & 16 below. The gas connection is located at the front right hand side of the fire. **Note : Before breaking into the gas supply a gas tightness test should be carried out to establish that the existing pipework is sound.**

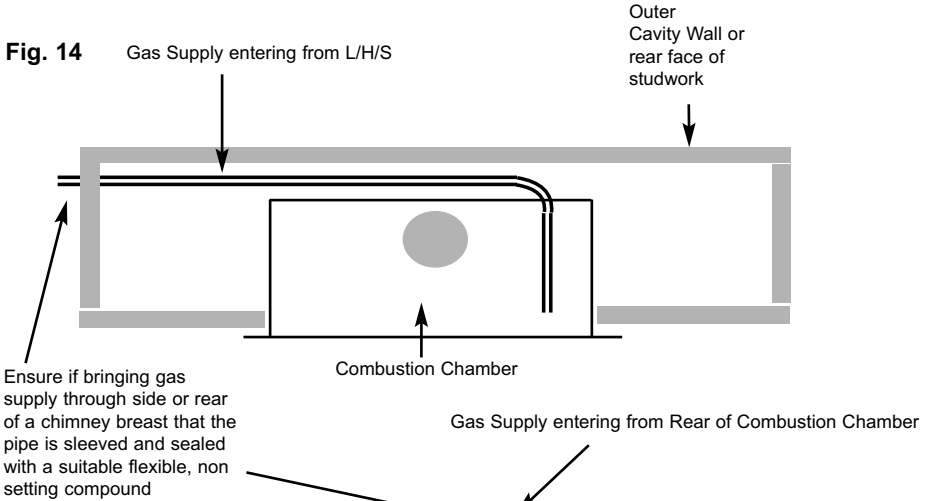

**Fig. 15**

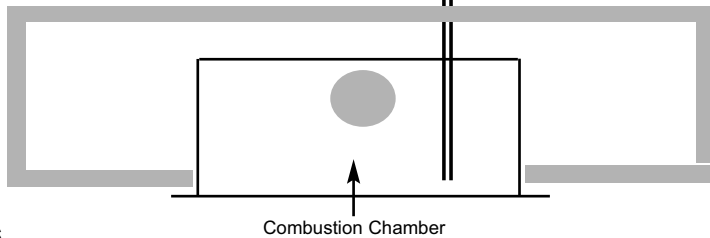

**Fig. 16**

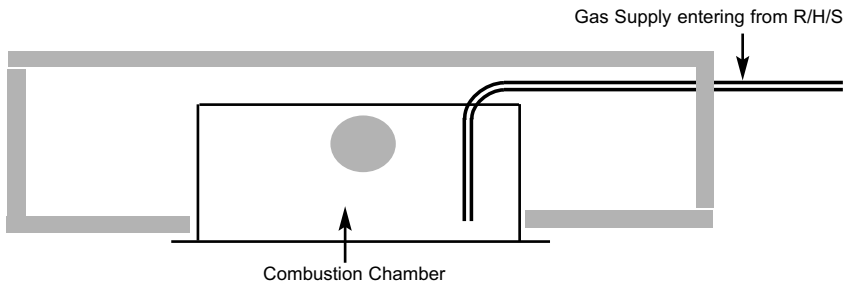

## 2.6 MAKING THE ELECTRICAL CONNECTION.

**WARNING :** THIS APPLIANCE MUST BE EARTHED AND SHOULD BE PREFERABLY CONNECTED VIA A 3 AMP SWITCHED FIXED FUSED SPUR WITH A MINIMUM CONTACT SEPARATION OF 3MM.  
IT MAY HOWEVER BE CONNECTED TO A 3 PIN PLUG TO BS 5733, THAT IS FITTED WITH A 3 AMP FUSE TO BS 1362.

- 2.6.1 The product is supplied with a mains cable and 3 pin plug fitted. The mains cable will exit the combustion chamber from the rear left hand side (viewed from the front), through the grommet. If the supply cord is damaged, it must be replaced by the manufacturer, it's service agent or similarly qualified persons in order to avoid a hazard.
- 2.6.2 Plug the mains cable supplied into a suitable socket in close proximity to the appliance or remove the plug and wire into a 3 amp switched fixed fused spur.

## 2.7 GAS TIGHTNESS AND INLET PRESSURE

- 2.7.1 Remove the pressure test point screw from the inlet elbow and fit a manometer.
- 2.7.2 Turn on the main gas supply and carry out a gas tightness test.
- 2.7.3 See section 3.3 for full details of the operating method for the fire.
- 2.7.4 Check that the gas pressure is **20.0 mbar (+/- 1.0mbar) 8.0 in w.g.(+/- 0.4 in w.g.)**
- 2.7.5 Turn off the fire, remove the manometer and refit the pressure test point screw. Check the pressure test point screw for gas tightness with the appliance turned on using a suitable leak detection fluid or detector.



## 2.8 INSTALLATION OF LAMP ASSEMBLIES

2.8.1 With the burner assembly removed as described in section 2.4, next remove the electrical connection cover as shown below in figure 17.

**Fig. 17**

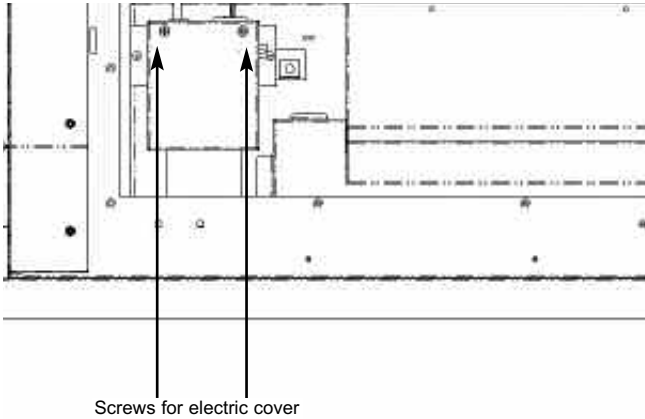

2.8.2 Remove two screws from electric cover (see figure 17) and remove cover, feed wiring from lamp assemblies through the grommet in the side of the fire and make connections as shown in figure 18 below.

**Fig. 18**

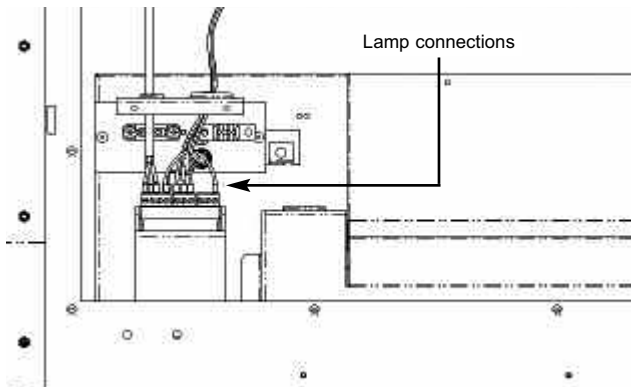

- 2.8.3 Re-assemble electrics cover, fan assembly and fan rear duct in reverse order.
- 2.8.4 Route lamp wiring up to surround shelf infill level ensuring that the wiring is kept clear of hot surfaces.
- 2.8.5 Fit the surround up to the point of the shelf infill (refer to section 2.9)
- 2.8.6 The surround lamp assemblies are then fitted to the surround using the two nuts provided, as shown in figure 19 below.
- 2.8.7 Fit the bulbs provided in the loose items pack as shown below in figure 19, then finally fit the surround shelf.

**Fig. 19 Shown from rear for clarity**

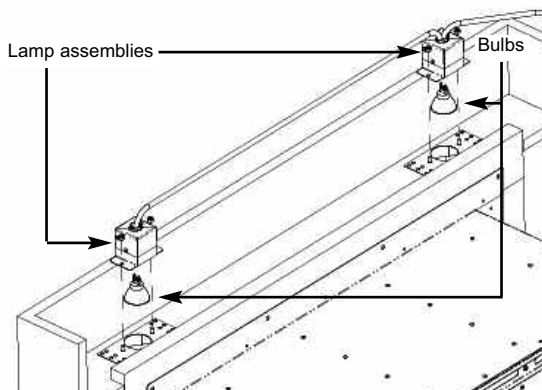

- 2.8.8 Re-fit the burner assembly

## **2.9        INSTALLATION OF THE PARADA ILLUMIA SURROUND**

- 2.9.1        Unpack the surround from the wooden crate, check all parts are present as per figure 4 on page 8 and carefully store the components.
- 2.9.2        The underside of the hearth should be painted with a weak PVA (8 parts water to 1 part PVA). This will prevent staining penetrating through the stone. The hearth must be centered to the opening. If the fireplace is to be installed on a chimney breast ensure that the opening is also centered to the chimney breast. It is essential that the hearth is completely level. The hearth must be bedded down on bonding or an equivalent material. Avoid cement based products and ensure the hearth is firmly fitted and well supported. Allow the bedding material to set before any weight is placed onto the hearth. Wipe off any surplus bonding material with a wet sponge.
- 2.9.3        Fit bottom section to hearth, ensure it is central before fixing with a suitable mastic adhesive.
- 2.9.4        Screw the fixing plates firmly into the rear faces of the legs with the screws and rawlplugs provided.
- 2.9.5        Place the side infills and legs in position using the shelf infill to gauge the correct width. Mark the fixing hole positions on the wall, remove the legs and side infills, cover the hearth with a dust sheet then drill the fixing holes and fit the rawlplugs. Fix the side infills into place with suitable adhesive and replace the legs, securing to the wall with the fixing brackets.
- 2.9.6        Fix the top infill and shelf infill into place again with suitable mastic adhesive.
- 2.9.7        Fit lamp assemblies into position as detailed in section 2.8.6 & 2.8.7.
- 2.9.8        Fit shelf into place ensuring it is correctly centered before sealing with adhesive.
- 2.9.9        Once the fireplace is correctly installed, grout all of the joints including between the fireplace and the wall with a water based cream mastic or tile grout. Ensure all surplus grout is immediately removed by washing the stonework using a sponge and clean water.

## SECTION 3 INSTALLATION OF FIRE

### 3.1 FITTING THE FUEL-BED LOGSET

**IF FITTING THE PRODUCT WITH THE PEBBLE FUELBED, PLEASE PROCEED TO SECTION 3.2**

- 3.1.1 The vermiculite material should then be first layed around the burner tray as shown below in figure 20, resulting in an even layer.

**Fig. 20**



- 3.1.2 Place Log "1" at the left hand side of the burner tray fitting the holes in the bottom face of the log onto the 2 off location pegs as shown below in figure 21.

**Fig. 21**



- 3.1.3 Place Log “2” at the right hand side centre of the burner tray fitting the hole in the bottom face of the log onto the single location peg as shown below in figure 22.

**Fig. 22**

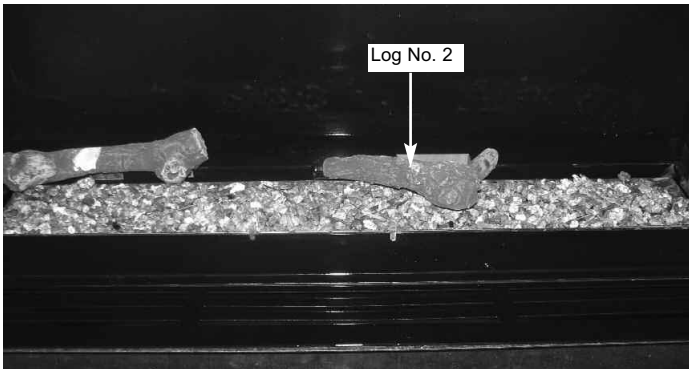

- 3.1.4 Place Log “3” at the right hand side of the burner tray fitting the hole in the bottom face of the log onto the single location peg as shown below in figure 23.

**Fig. 23**



- 3.1.4 Place Log "4" at the centre of the burner tray fitting the holes in the bottom face of the log onto the 2 off location pegs as shown below in figure 24.

**Fig. 24**



- 3.1.5 Place Log "5" at the right hand side of the burner tray locating in the groove of Log "3" as shown below in figure 25.

**Fig. 25**

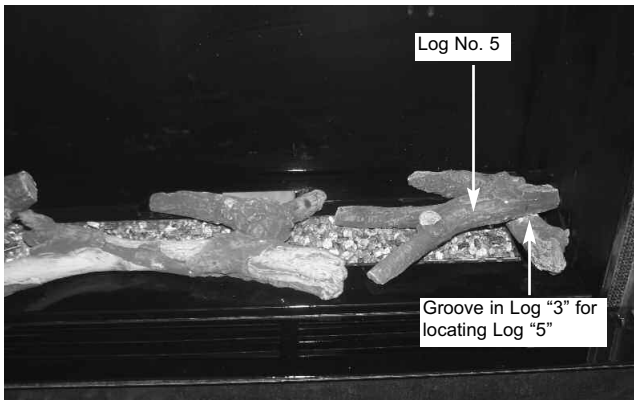

3.1.6 Place Log “6” at the left hand side of the burner tray locating in the groove of Log “1” as shown below in figure 26.

**Fig. 26**

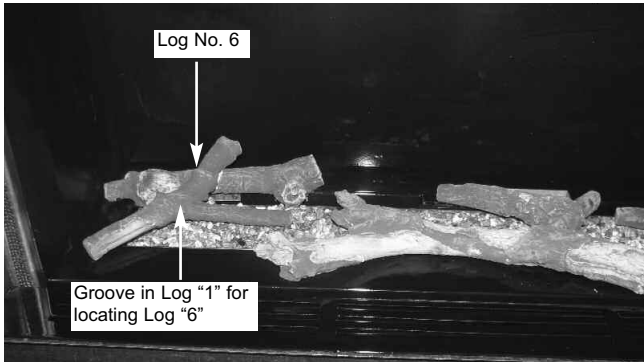

3.1.7 Place Log “7” to the left hand centre side of the burner tray locating on the branch of Log “1” as shown below in figure 27.

**Fig. 27**

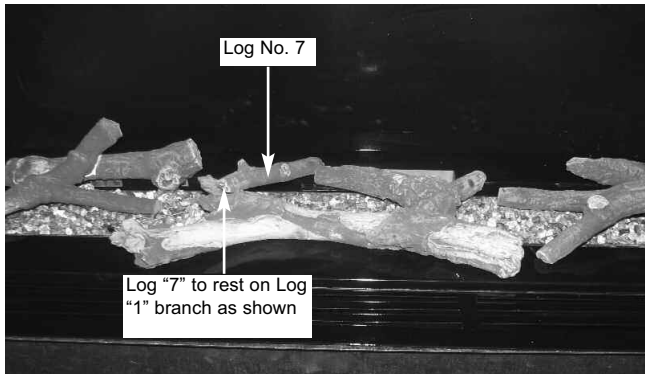

- 3.1.8 If required, fit the glow fibre material over the flame ports. To do this, separate into short strands and place randomly over the flame porting area as shown below in figure 28. **This material is only supplied to improve flame aesthetics and is optional to install.**

**Fig. 28**

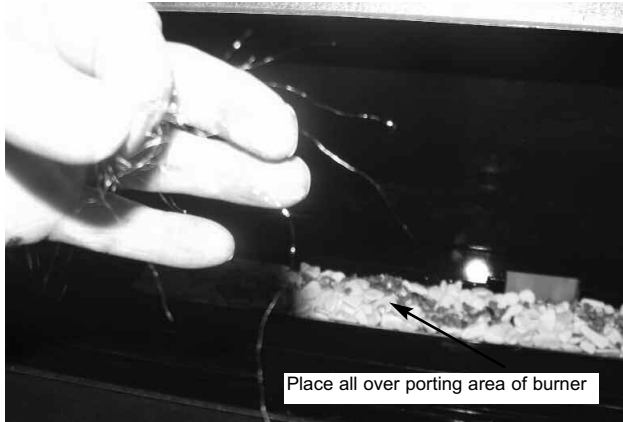

- 3.1.9 Refit the glass panel as described in section 2.2, then light the appliance as described as in section 3.3

**IMPORTANT NOTE : PLEASE ENSURE THAT WHEN COMMISSIONING THE FIRE THE FLAME PATTERN IS EVEN ACROSS THE WIDTH OF THE BURNER. IF AN UNEVEN FLAME PATTERN IS FOUND THEN RELAY THE QUANTITY VERMICULITE TO ACHIEVE AN EVEN FLAME PATTERN.**

**Warning :** Use only the logs supplied with the fire. When replacing the logs remove the old logs and discard them. Fit a complete set of logs of the correct type. Do not fit additional logs or any logs other than a genuine replacement set.

**This appliance does not contain any component manufactured from asbestos or asbestos related products.**



## 3.2 FITTING THE FUEL-BED PEBBLES

- 3.2.1 Remove the log retaining brackets (which are held in place by self tapping screws) from the fuel-bed support plate and retain them in a safe place. Fold the log retaining bracket mounted to the burner to the flat position. Fit the pebbles to the burner tray as shown below in figure 29, do not fill the flame ports in the burner with pebbles.

Fig. 29



- 3.2.2 Fit the vermiculite material into the burner ports as shown below in figure 30. **This material must be fitted in an even layer to ensure correct operation of the fire.**

Fig. 30

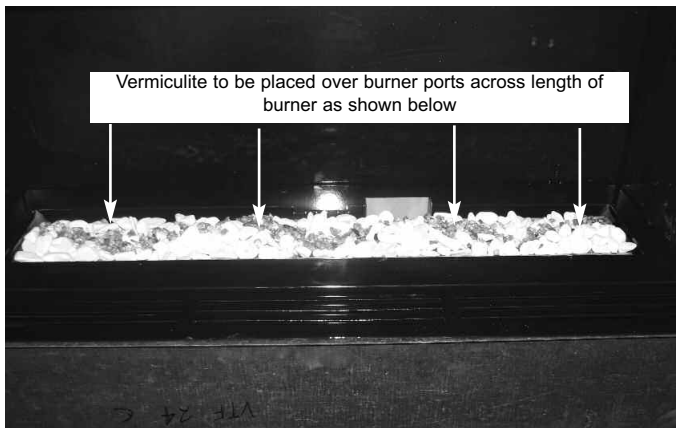

- 3.2.3 If required, fit the embaglow material over the flame ports. To do this, separate into short strands and place randomly over the flame porting area as shown on previous page in figure 28. **This material is only supplied to improve flame aesthetics and is optional to install.**
- 3.2.4 Refit the glass panel as described in section 2.2, then light the appliance as described as in section 3.3

### 3.3 LIGHTING THE APPLIANCE

**IMPORTANT** : IF THE BURNER IS EXTINGUISHED FOR ANY REASON YOU MUST ENSURE THAT YOU WAIT A FULL FIVE MINUTES BEFORE ATTEMPTING TO RE-LIGHT THE FIRE.

The product is controlled by the remote handset supplied with the fire. Ensure the 3 off AAA batteries as supplied in the loose items pack have been fitted to the remote handset before attempting to use the handset and the mains electrical connection has been made to the product as per section 2.6

There are 5 modes of operation of the product, “MANUAL mode”, “TEMPERATURE mode”, “TIMER mode”, “LIGHTING / DIMMER” mode and “CIRCULATING FAN” mode.

#### 3.3.1 Operation of the Fire in “MANUAL” mode

- 3.3.1.1 Locate the ON/OFF switch on the appliance, it is situated as shown below in figure 31. Ensure that the on / off switch is in the “ON” (1) position.

**Fig. 31**

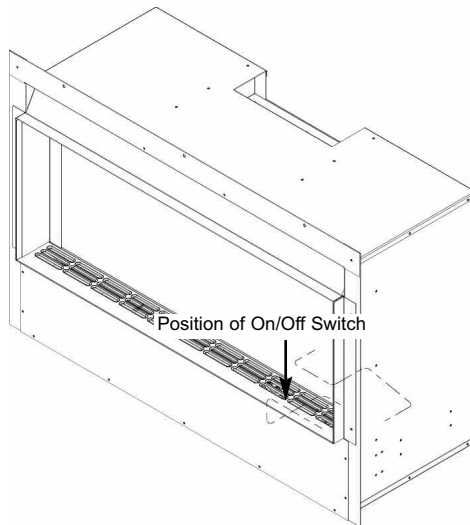

3.2.1.2 The remote handset is now used to control all functions of the fire. To light the fire, press the “UP” arrow and and “OFF” button simultateously as shown on figure 32 below. You will hear a click and the fire begins a 30 second ignition process. The pilot and main burner will light. The appliance is now in “MANUAL mode” which will be shown via the “MAN” graphic on the display of the handset as shown below in figure 32.

**Fig. 32**

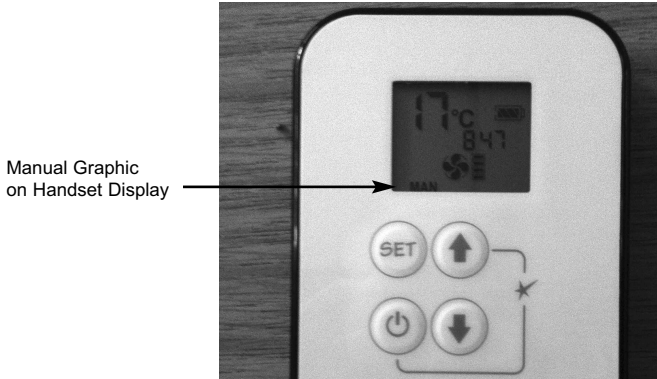

3.3.1.3 With the product in “MANUAL” mode the fire can now be switched between HIGH rate heat input and LOW rate heat input by pressing the “DOWN” arrow on the handset. To reduce the flame height of the main burner incrementally, press the arrow momentarily. To reduce the heat input directly down to the minimum level, press the “SMALL” flame arrow on the handset twice, “LO” will be displayed. NOTE : The flame will go to HIGH rate heat input before going to designated LOW rate heat input. To return back to HIGH rate heat input press the “LARGE” flame button twice. To put the fire in In “STANDBY MODE” (only the pilot remains lit) press and hold the “SMALL” flame arrow on the handset. See figure 33 below.

**Fig. 33**

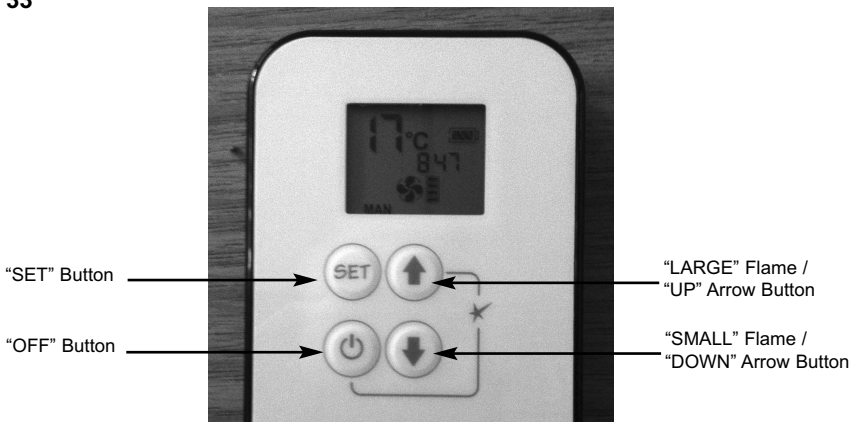

3.2.1.4 To turn the fire off, press the “OFF” button, this will extinguish all flames including the pilot.

### 3.3.2 Operation of the Fire in “TEMPERATURE” mode

3.3.2.1 In order to change the mode of operation from “MANUAL” to “TEMPERATURE”, press the “SET” button, the fire will then change to either “DAY TEMP” (figure 34) mode or “NIGHT TEMP” mode (figure 35). To alternate between the 2, press the “SET” button. **The display on the handset will show the current temperature in the room.**

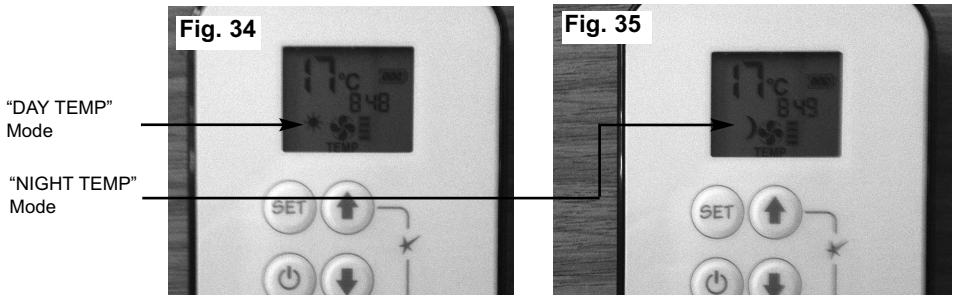

**NOTE :** The “SET” button allows you to alternate between all modes of operation :- “MANUAL”, “DAY TEMP”, “NIGHT TEMP”, “TIMER”, “LIGHT / DIMMER” and “CIRCULATING FAN” then back to “MANUAL”. Alternatively, pressing either the “UP” or “DOWN” arrow allows the unit to revert to “MANUAL” mode. **Fire must be in standby mode (pilot must be lit) for temperature mode to be used.**

3.3.2.2 Within the “TEMPERATURE” mode there are options for either “DAY TEMP” or “NIGHT TEMP”. These temperatures can be set independently to allow a higher temperature to be maintained at night than during the day, or if setting the same temperature for day and night the fire will compensate for the generally cooler evening temperatures and automatically increase the heat input level accordingly.

3.2.2.3 To set the temperature, ensure the handset is in “TEMPERATURE” mode and then press the “SET” button until the “TEMP” display flashes then let go. Proceed to set the desired temperature by pressing the “UP” (large flame) or “DOWN” (small flame) arrows as necessary, then press “OFF” to complete the process.

NOTE : Minimum temperature is 5°C, Maximum temperature is 30°C, or minimum 41F to maximum 86F when in Fahrenheit mode.

3.2.2.4 Press the “OFF” button to stop the display flashing or wait to return to “TEMPERATURE” mode. NOTE : If you set a temperature below the current room temperature the fire will switch to standby mode (pilot

burner only) until the room has cooled to the temperature you have set on the handset display.

- 3.3.2.5 If you would like the “NIGHT TEMP” to turn the fire off then decrease the temperature until [----] is displayed.

### 3.3.3 Operation of the Fire in “TIMER” mode

- 3.3.3.1 In order to change the mode of operation from “MANUAL” to “TIMER”, press the “SET” button, the fire will then alternate between the settings until the “TIMER” mode is displayed.

**NOTE :** The “SET” button allows you to alternate between all modes of operation :- “MANUAL”, “DAY TEMP”, “NIGHT TEMP”, “TIMER” and back to “MANUAL”. Alternatively, pressing either the “UP” or “DOWN” arrow allows the unit to revert to “MANUAL” mode. **Fire must be in standby mode (pilot must be lit) for temperature mode to be used.**

- 3.3.3.2 Within the “TIMER” setting mode there are two programmable settings you can make over a 24 hour period, namely P1 and P2. To set the timer, ensure the handset is in “TIMER” mode as detailed in section 3.3.3.1 above.

- 3.3.3.3 To set the P1 timed start setting, press and hold the “SET” button until the P1 (sun symbol is displayed as per figure 36 below) and the time flashes. Set the hour by pressing the “UP” (large flame) and set the minutes (in ten minute increments) by pressing the “DOWN” (small flame) as necessary, then press “OFF” button to complete the process. Repeat for the P1 (moon symbol is displayed as per figure below) Set the hour by pressing the “UP” (large flame) and set the minutes (in ten minute increments) by pressing the “DOWN” (small flame) as necessary, then press “OFF” button to complete the process.

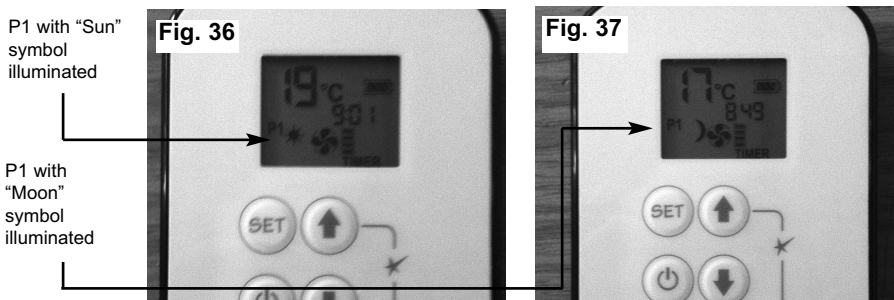

3.3.3.4 To set the P2 timed setting, press the “SET” button until the “TIMER” mode is displayed. Hold the “SET” button until the display flashes the current time for P1. Press the “SET” button again to scroll past the setting for P1 (sun) and P1 (moon). The time should now be flashing on the handset. Set the hour by pressing the “UP” (large flame) and set the minutes (in ten minute increments) by pressing the “DOWN” (small flame) as necessary, then press “OFF” button to complete the process.

### 3.3.4 Operation of the Fire in “LIGHT / DIMMER” mode

3.3.4.1 In order to change the mode of operation from “MANUAL” to “LIGHT / DIMMER”, briefly press the “SET” button to scroll through to the light bulb mode as shown below in figure 38.

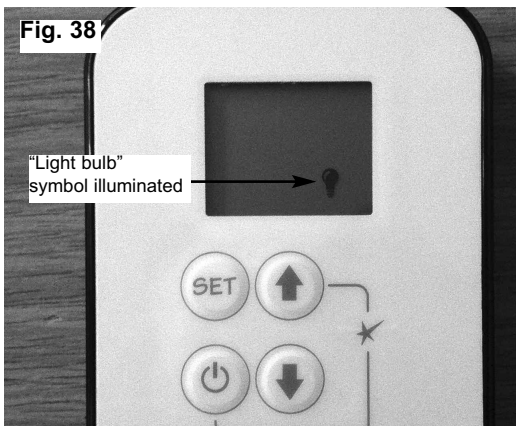

3.3.4.2 Press and hold the “LARGE” flame button to turn on the light or increase brightness.

3.3.4.3 Press and hold the “SMALL” flame button to decrease the brightness.

3.3.4.4 In the light / dimmer mode the “OFF” button shuts off the light, if you want the light on but no flame, press and hold the “SMALL” flame button and turn to pilot flame.

**NOTE :** The light bulb is displayed during light / dimmer setting only. 8 seconds after the light/dimmer has been set, the handset will automatically go into manual mode.

### 3.3.5 Operation of the Fire in “CIRCULATING FAN” mode

- 3.3.5.1 In order to change the mode of operation from “MANUAL” to “CIRCULATING FAN”, briefly press the “SET” button to scroll through to the circulating fan mode as shown below in figure 39 / 40, both fan and level icons will flash.

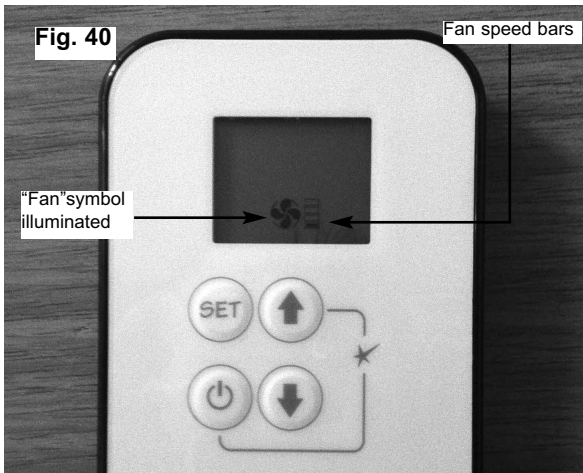
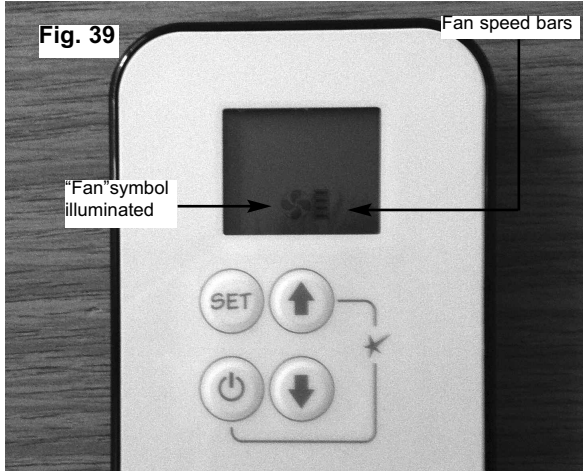

- 3.3.5.2 Press and hold the “LARGE” flame button to turn on the fan and increase fan speed.
- 3.3.5.3 Press and hold the “SMALL” flame button to decrease the fan speed, see figure 39 / 40 for fan speed bar indicator (4 bars illuminated = maximum fan speed, 1 bar illuminated = minimum fan speed).

- 3.3.5.4 To turn the fan off press and hold the “SMALL” flame button until all 4 speed level bars disappear.

**NOTE** : 8 seconds after the light/dimmer has been set, the handset will automatically go into manual mode. The fan starts 4 minutes after the gas supply opens (from OFF or from pilot) at maximum speed and goes to the displayed level after 10 seconds. The fan stops 10 minutes after the gas is off or a pilot only (standby mode).

**IT IS RECOMMENDED FOR MOST EFFICIENT PERFORMANCE OF THE PRODUCT THE FAN MODE IS SET TO THE MAXIMUM (ALL FOUR SPEED BARS) POSITION.**

### **3.3.6 Low Battery Signal**

- 3.3.6.1 When the battery in the handset needs replacing, “BATT” will be displayed on the handset.
- 3.3.6.2 Remove the cover on the rear of the handset and replace the 3 off AAA batteries as necessary.

### **3.3.7 To Set the Time on the Remote Handset**

- 3.3.7.1 Simultaneously press the “UP” (large flame) arrow and “DOWN” (small flame) arrow buttons on the remote handset.
- 3.3.7.2 Press the “UP” (large flame) arrow to set the hour and the “DOWN” (small flame) arrow to set the minutes.

### **3.3.8 To Set the °C / 24 Hour or °F / 12 Hour Clock**

- 3.3.8.1 Press and hold the “OFF” and the “DOWN” (small flame) arrow buttons on the handset simultaneously until the display changes from °C to °F and vice versa.

### **3.3.9 FITTING THE HANDSET WALL BRACKET / DIMMER LIGHT BULBS**

- 3.3.9.1 The wall bracket is supplied in the loose items pack and is optional to fit.
- 3.3.9.2 If fitting the wall bracket, **please be advised that the thermostatic sensor is contained within the handset itself, so the position of the wall bracket will therefore be the position of temperature measurement within the room.** To fit, position as necessary, mark hole positions, drill and secure with fixings provided.



- 3.3.9.3 Fit the bulbs as supplied in the loose items pack (into the surround design as applicable), wiring should be completed by a competent person into the V module in the base of the fire in accordance with section 2.8 and the wiring diagram supplied for the fire on page 37, section 4.9

### **3.3.10 INSTRUCTING THE USER / PRODUCT HANDOVER**

- 3.3.10.1 Instruct the user on the operation of the fire and the handset.
- 3.3.10.2 Hand the glass clamp over and advise the customer to store it in a safe place.

### **3.4 REMOVAL / RE-FITTING OF THE EFFICIENCY BAFFLE**

- 3.4.1 Remove the glass panel as shown in section 2.2
- 3.4.2 The efficiency baffle if fitted to the inner roof of the combustion chamber and is secured by 2 off screws.
- 3.4.3 Remove the screws and pull the efficiency baffle downwards to remove from the appliance.
- 3.4.4 Replace in reverse order.

### **3.5 FITTING THE HANDSET WALL BRACKET**

- 3.5.1 The wall bracket is supplied in the loose items pack and is optional to fit.
- 3.5.2 If fitting the wall bracket, please be advised that the thermostatic sensor is contained within the handset itself, so the position of the wall bracket will therefore be the position of temperature measurement within the room. To fit, position as necessary, mark hole positions, drill and secure with fixings provided.

### 3.6 CHECKING FOR CLEARANCE OF COMBUSTION PRODUCTS

- 3.6.1 Close all doors and windows in the room.
- 3.6.2 Light the fire and allow to run for approximately 5 minutes on high position.
- 3.6.3 After approximately 5 minutes hold a smoke match just inside and below the centre of the lower front canopy at the top of the fire (see figure 41 below). It is recommended that a suitable smoke match holder is used when checking for clearance of combustion products). All smoke generated should be drawn back into the flue. If slight spillage occurs or if in doubt, repeat the test after a further 5-10 minutes. **If the test indicates that spillage is occurring and the flue restrictor baffle has been fitted, it should be removed (see section 3.4) and the test repeated after the fire has cooled.**
- 3.6.4 If spillage persists, the flue is not functioning correctly and a fault exists. If, after investigation the fault cannot be traced and rectified, the fire must be disconnected from the gas supply and expert advice obtained.
- 3.6.5 If there is an extractor fan fitted any where in the vicinity of the appliance, or in adjacent rooms the spillage test should be repeated with the fan running on maximum and all interconnecting doors open. After ensuring that the fire is safe to use it should be left on high

**Fig. 41**

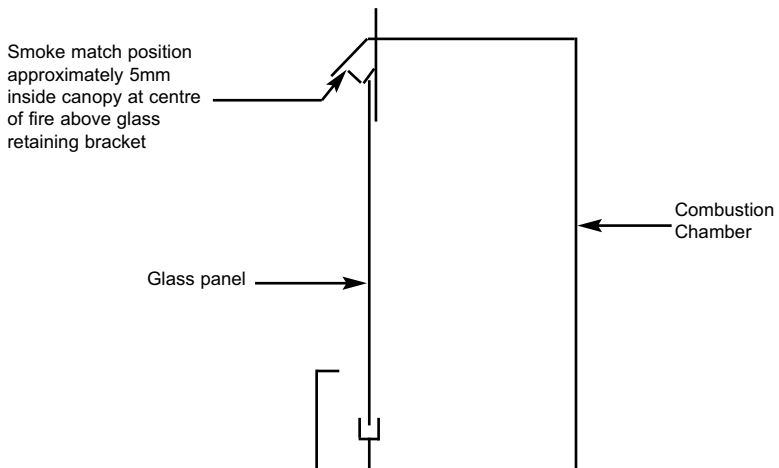

## SECTION 4 MAINTENANCE

### Servicing Notes

Servicing should be carried out annually by a competent person such as a GAS SAFE registered engineer. **This is a condition of the guarantee schemes.** The service should include visually checking the chimney and fire opening for accumulations of debris and a smoke test to check for a positive up-draught in the chimney. To access the debris collection void a removeable plate is positioned on the rear face of the firebox box behind the burner. The oxypilot on the burner unit must also be changed annually as a condition of the guarantee. The condition of the fuel-bed should be checked and **if necessary the whole item should be replaced with a genuine replacement item.** The burner assembly is designed to be removed as a complete unit for ease of access. **After any servicing work a gas tightness check must always be carried out.**

**BEFORE ANY SERVICING WORK IS CARRIED OUT ENSURE THE PRODUCT HAS BEEN DISCONNECTED FROM THE ELECTRICITY SUPPLY. ALL ELECTRICAL REPAIR WORK MUST BE CARRIED OUT BY A COMPETENT, QUALIFIED ELECTRICIAN.**

#### **4.1 Removing the burner assembly from the fire.**

4.1.1 Prepare work area (lay down dust sheets etc.)

4.1.2 Remove the glass assembly, remove the ceramic logs and vermiculite.

4.1.3 Lift the burner tray clear, then unscrew and remove the eight off screws which hold the burner in position & then disconnect the main Isolate the gas supply and remove the supply pipe from the appliance inlet elbow. Disconnect the wiring connector from the V module.

4.1.4 To refit the burner assembly, locate the burner unit and refit the eight off screws. Re-connect the wiring connector. Refit the burner tray. Refit the gas supply pipe and carry out a gas tightness test. Refit the fuel-bed referring to section 3 for the correct log positions. Re-fit the glass frame assembly, grill (held in position by two screws) and side trims.

#### **4.2 Removing the gas control valve from the fire.**

4.2.1 Remove the burner from the combustion chamber as described in section 4.1 above.

4.2.2 Disconnect the inlet, outlet, pilot pipes and thermocouple connection from the control valve.

4.2.3 Replace in reverse order and carry out a gas tightness test.

### **4.3 Removing the ultrasonic receiver.**

- 4.3.1 Remove the burner from the combustion chamber as described in section 4.1.
- 4.3.2 Disconnect the control wires from the receiver.
- 4.3.3 Disconnect the ignition wire.
- 4.3.4 Re-fit the new receiver and re-fit the control wires to the control valve.
- 4.3.5 Re-assemble the burner unit to the combustion chamber and carry out a gas tightness test.

### **4.4 Removing the pilot assembly**

- 4.4.1 Remove the burner from the combustion chamber as described in section 4.1.
- 4.4.2 Disconnect the pilot supply pipe, ignition wire and thermocouple connection to the gas control valve.
- 4.4.3 Remove the pilot retaining screws and lift the pilot assembly clear
- 4.4.4 Re-assemble in reverse order and carry out a gas tightness test.

### **4.5 Removing the convection fan**

- 4.5.1 Remove the burner from the combustion chamber as described in section 4.1.
- 4.5.2 Ensure that the electrical supply to the fire is isolated.
- 4.5.3 Disconnect the wiring to the motor on the convection fan
- 4.5.4 Remove the retaining screws that hold the convection fan assembly to the base of the combustion chamber.
- 4.5.5 Lift the convection fan assembly clear if required.
- 4.5.6 Re-assemble in reverse order.

### **4.6 Replacing the batteries in the handset**

- 4.6.1 Remove and re-fit the new 3 off AAA batteries by removing the cover on the back of the handset.

## **4.7 Checking for flue debris**

- 4.7.1 Remove the burner assembly as detailed in section 4.1
- 4.7.2 Locate the removeable backplate on the rear face of the firebox at the bottom.
- 4.7.3 Remove the 2 screws that hold the removeable backplate on the rear face of the firebox.
- 4.7.4 Remove any debris.
- 4.7.5 Replace the removeable backplate on the rear face of the firebox.
- 4.7.6 Re-assemble in reverse order and carry out a gas tightness test.

## **4.8 Parts shortlist**

B-92200	GV60 Gas control valve
B-93300	GV60 Thermocouple Interrupter
B-153140	GV60 Receiver unit
B-153160	GV60 Control module
B-153150	GV60 Remote control thermostatic handset
B-153720	GV60 8 wire cable
B-153170	GV60 V module control cable
CV-104931	GV60 On/off switch with cables
CV-104934	Ignition cable
B-153080	2 metre mains cable
B-128120	Convection fan
B-152930	Wiring loom - GV60 control module to convection fan
1161-162790	Glass frame assembly
B-128240	Complete log set
B-128250	Log 1 only
B-128260	Log 2 only
B-128270	Log 3 only
B-128280	Log 4 only
B-128290	Log 5 only
B-128300	Log 6 only
B-128310	Log 7 only
B-120070	Glow Fibre
B-128320	Pebble set
CV-107116	Vermiculite

## 4.9 Wiring Diagram

Fig. 42

**IMPORTANT : ALL ELECTRICAL WORK MUST BE CARRIED OUT BY A COMPETENT, QUALIFIED ELECTRICIAN.**

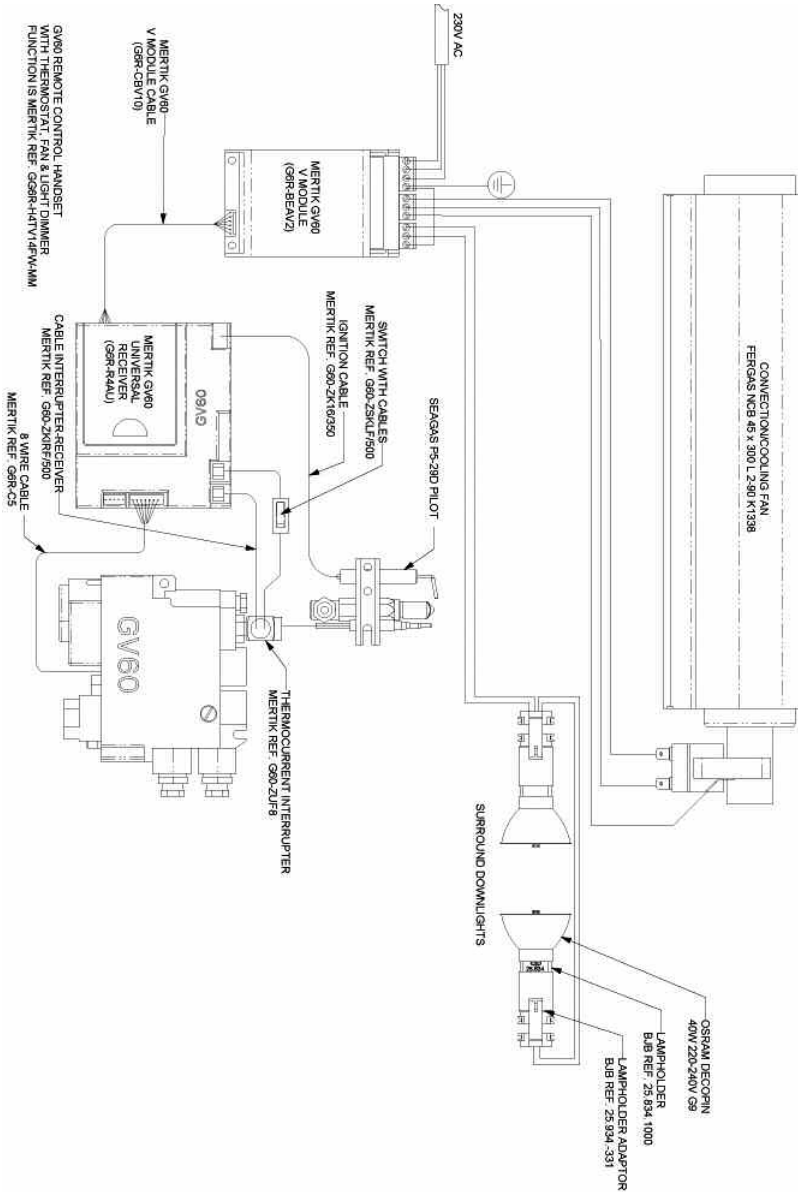

## SECTION FIVE - USER INSTRUCTIONS

### 5.1 INSTALLATION INFORMATION

#### CONDITIONS OF INSTALLATION

It is the law that all gas appliances are installed only by a competent (e.g. Registered) Installer, in accordance with the installation instructions and the Gas Safety (Installation and Use) Regulations 1998. Failure to install appliances correctly could lead to prosecution. It is in your own interest and that of safety to comply with the law.

The fire may be fitted below a combustible shelf (when fitted with surrounds other than available from The Collection) provided that the shelf is at least 300mm above the top of the appliance and the depth of the shelf does not exceed 150mm.

The fire may be installed below combustible shelves (when fitted with surrounds other than available from The Collection) which exceed 150mm deep providing that the clearance above the fire is increased by 15mm for each 25mm of additional overhang in excess of 150mm.

**No purpose made additional ventilation is normally required for this appliance when installed in G.B. When installed I.E. please consult document I.S. 813 : 1996 Domestic Gas Installation which is issued by the National Standards Authority of Ireland. Any purpose made ventilation should be checked periodically to ensure that it is free from obstruction.**

If the chimney or flue has been previously used by appliances burning fuels other than gas they must be swept prior to the installation of this fire.

If this appliance is fitted directly on to a wall without the use of a fireplace or surround, soft wall coverings such as wallpaper, blown vinyl etc. could be affected by the heat and hot convection air and may discolour or scorch. This should be considered when installing or decorating.

The Model number of this appliance is as stated on the rating plate affixed to the control panel of the fire and the appliance is manufactured by:-

BFM Europe Ltd  
Trentham Lakes  
Stoke on Trent  
ST4 4TJ

## 5.2 ABOUT YOUR NEW PARADA ILLUMIA GAS FIRE

The Collection “Parada Illumia” log effect gas fires incorporate a unique and highly developed fuel bed which gives the realism of a loose log layout combined with realistic flames and glow. The use of durable ceramic material in the construction of the fuelbed components ensures long and trouble free operation.

Please take the time to fully read these instructions as you will then be able to obtain the most effective and safe operation of your fire.

### IMPORTANT SAFETY INFORMATION

#### WARNING

**This appliance is a heating appliance and as with all heating appliances a fireguard should be used for the protection of children, the elderly and infirm. Fireguards should conform to B.S. 8423 : 2002 (Fireguards for use with gas heating appliances).**

It is important that this appliance is serviced at least once a year by a GAS SAFE registered engineer. During the annual service, replacement of the oxy-pilot must be carried out. **This is a condition of the manufacturers guarantee.** Any debris or deposits should be removed from the fuel bed from time to time. This may be carried out by referring to the cleaning section as described later in this book.

Only the correct number and type of logs must be used and only complete and genuine replacement sets must be used. Always keep furniture and combustible materials well clear of the fire and never dry clothing or items either on or near to the fire. Never use aerosols or flammable cleaning products near to the fire when it is in use.

**The ceramic fuel bed remains hot for a considerable period after use and sufficient time should be allowed for the fire to cool before cleaning etc.**

#### IMPORTANT NOTES :

**DO NOT UNDER ANY CIRCUMSTANCES USE THIS FIRE IF THE GLASS PANEL IS BROKEN, CRACKED OR MISSING.**

**THIS APPLIANCE IS NOT INTENDED FOR USE BY PERSONS (INCLUDING CHILDREN) WITH REDUCED PHYSICAL, SENSORY OR MENTAL CAPABILITIES, OR LACK OF EXPERIENCE AND KNOWLEDGE, UNLESS THEY HAVE BEEN GIVEN SUPERVISION OR INSTRUCTION CONCERNING USE OF THE APPLIANCE BY A PERSON RESPONSIBLE FOR THEIR SAFETY. CHILDREN SHOULD BE SUPERVISED TO ENSURE THAT THEY DO NOT PLAY WITH THE APPLIANCE. ANY ELECTRICAL WORK MUST BE CARRIED OUT BY A COMPETENT, QUALIFIED ELECTRICIAN. THIS APPLIANCE CAN BE USED BY CHILDREN AGED 8 YEARS AND ABOVE AND PERSONS WITH REDUCED PHYSICAL, SENSORY OR MENTAL CAPABILITIES OR LACK OF EXPERIENCE AND KNOWLEDGE IF THEY HAVE BEEN GIVEN SUPERVISION OR INSTRUCTION CONCERNING USE OF THE APPLIANCE IN A SAFE WAY AND UNDERSTAND THE HAZARDS INVOLVED. CHILDREN SHALL NOT PLAY WITH THE APPLIANCE. CLEANING AND USER MAINTENANCE SHALL NOT BE MADE BY CHILDREN WITHOUT SUPERVISION.**



## 5.3 LIGHTING THE FIRE / USER CONTROLS

**IMPORTANT : IF THE BURNER IS EXTINGUISHED FOR ANY REASON YOU MUST ENSURE THAT YOU WAIT A FULL THREE MINUTES BEFORE ATTEMPTING TO RE-LIGHT THE FIRE.**

The product is controlled by the remote handset supplied with the fire. Ensure the 3 off AAA batteries as supplied in the loose items pack have been fitted to the remote handset before attempting to use the handset. There are 5 modes of operation of the product, “MANUAL mode”, “TEMPERATURE mode”, “TIMER mode”, “LIGHTING / DIMMER” mode and “CIRCULATING FAN” mode.

### 5.3.1 Operation of the Fire in “MANUAL” mode

5.3.1.1 Locate the ON/OFF switch on the appliance, it is situated as shown below in figure 1. Ensure that the on / off switch is in the “ON” (1) position.

**Fig. 1**

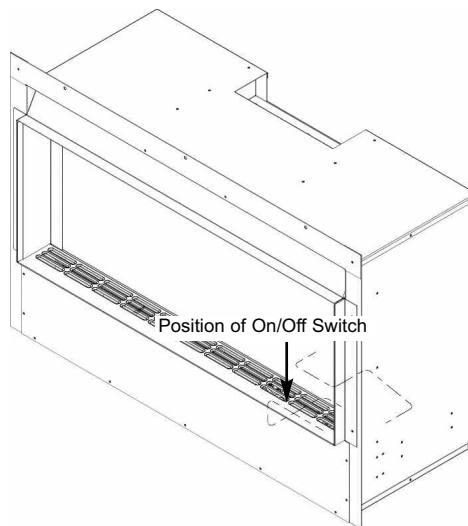

5.3.1.2 The remote handset is now used to control all functions of the fire. To light the fire, press the “UP” arrow and and “OFF” button simultaneously as shown on figure 2 overpage. You will hear a click and the fire begins a 30 second ignition process. The pilot and main burner will light. The appliance is now in “MANUAL mode” which will be shown via the “MAN” graphic on the display of the handset as shown overpage in figure 2.

**Fig. 2**

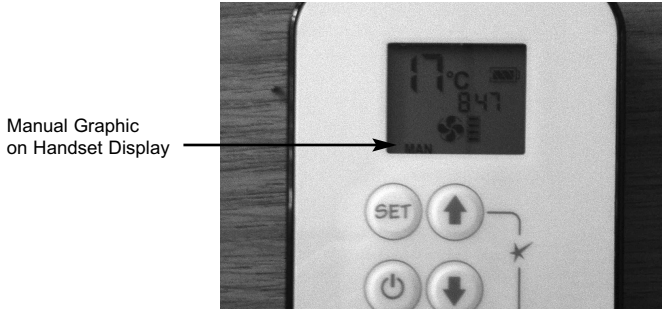

5.3.1.3 With the product in “MANUAL” mode the fire can now be switched between HIGH rate heat input and LOW rate heat input by pressing the “DOWN” arrow on the handset. To reduce the flame height of the main burner incrementally, press the arrow momentarily. To reduce the heat input directly down to the minimum level, press the “SMALL” flame arrow on the handset twice, “LO” will be displayed. NOTE : The flame will go to HIGH rate heat input before going to designated LOW rate heat input. To return back to HIGH rate heat input press the “LARGE” flame button twice. To put the fire in In “STANDBY MODE” (only the pilot remains lit) press and hold the “SMALL” flame arrow on the handset. See figure 3 below.

**Fig. 3**

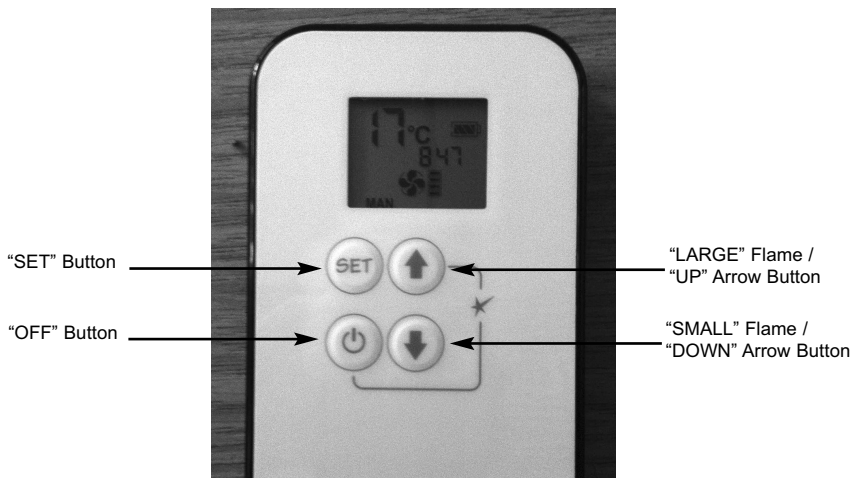

5.3.1.4 To turn the fire off, press the “OFF” button, this will extinguish all flames including the pilot.

### 5.3.2 Operation of the Fire in “TEMPERATURE” mode

5.3.2.1 In order to change the mode of operation from “MANUAL” to “TEMPERATURE”, press the “SET” button, the fire will then change to either “DAY TEMP” (figure 4) mode or “NIGHT TEMP” mode (figure 5). To alternate between the 2, press the “SET” button. **The display on the handset will show the current temperature in the room.**

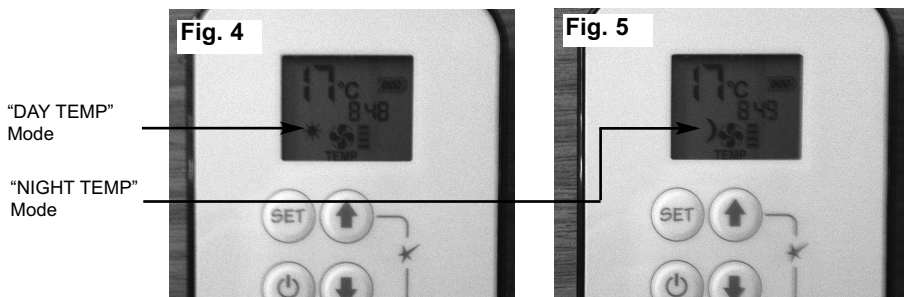

**NOTE :** The “SET” button allows you to alternate between all modes of operation :- “MANUAL”, “DAY TEMP”, “NIGHT TEMP”, “TIMER”, “LIGHT / DIMMER” and “CIRCULATING FAN” then back to “MANUAL”. Alternatively, pressing either the “UP” or “DOWN” arrow allows the unit to revert to “MANUAL” mode. **Fire must be in standby mode (pilot must be lit) for temperature mode to be used.**

5.3.2.2 Within the “TEMPERATURE” mode there are options for either “DAY TEMP” or “NIGHT TEMP”. These temperatures can be set independently to allow a higher temperature to be maintained at night than during the day, or if setting the same temperature for day and night the fire will compensate for the generally cooler evening temperatures and automatically increase the heat input level accordingly.

5.3.2.3 To set the temperature, ensure the handset is in “TEMPERATURE” mode and then press the “SET” button until the “TEMP” display flashes then let go. Proceed to set the desired temperature by pressing the “UP” (large flame) or “DOWN” (small flame) arrows as necessary, then press “OFF” to complete the process.  
**NOTE :** Minimum temperature is 5°C, Maximum temperature is 30°C, or minimum 41F to maximum 86F when in Fahrenheit mode.

5.3.2.4 Press the “OFF” button to stop the display flashing or wait to return to “TEMPERATURE” mode. **NOTE :** If you set a temperature below the current room temperature the fire will switch to standby mode (pilot burner only) until the room has cooled to the temperature you have set on the handset display.

5.3.2.5 If you would like the “NIGHT TEMP” to turn the fire off then decrease the temperature until [----] is displayed.

### 5.3.3 Operation of the Fire in “TIMER” mode

5.3.3.1 In order to change the mode of operation from “MANUAL” to “TIMER”, press the “SET” button, the fire will then alternate between the settings until the “TIMER” mode is displayed.

**NOTE :** The “SET” button allows you to alternate between all modes of operation :- “MANUAL”, “DAY TEMP”, “NIGHT TEMP”, “TIMER” and back to “MANUAL”. Alternatively, pressing either the “UP” or “DOWN” arrow allows the unit to revert to “MANUAL” mode. **Fire must be in standby mode (pilot must be lit) for temperature mode to be used.**

5.3.3.2 Within the “TIMER” setting mode there are two programmable settings you can make over a 24 hour period, namely P1 and P2. To set the timer, ensure the handset is in “TIMER” mode as detailed in section 5.3.3.1 above.

5.3.3.3 To set the P1 timed start setting, press and hold the “SET” button until the P1 (sun symbol is displayed as per figure 6 below) and the time flashes. Set the hour by pressing the “UP” (large flame) and set the minutes (in ten minute increments) by pressing the “DOWN” (small flame) as necessary, then press “OFF” button to complete the process. Repeat for the P1 (moon symbol is displayed as per figure below) Set the hour by pressing the “UP” (large flame) and set the minutes (in ten minute increments) by pressing the “DOWN” (small flame) as necessary, then press “OFF” button to complete the process.

P1 with “Sun”  
symbol  
illuminated

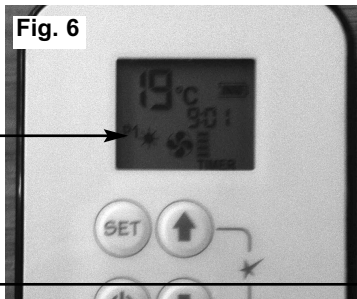

P1 with  
“Moon”  
symbol  
illuminated

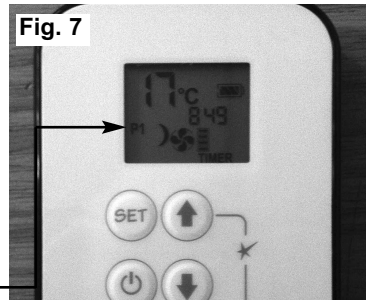

### 5.3.4 Operation of the Fire in “LIGHT / DIMMER” mode

- 5.3.4.1 In order to change the mode of operation from “MANUAL” to “LIGHT / DIMMER”, briefly press the “SET” button to scroll through to the light bulb mode as shown below in figure 8.

Fig. 8



- 5.3.4.2 Press and hold the “LARGE” flame button to turn on the light or increase brightness.
- 5.3.4.3 Press and hold the “SMALL” flame button to decrease the brightness.
- 5.3.4.4 In the light / dimmer mode the “OFF” button shuts off the light, if you want the light on but no flame, press and hold the “SMALL” flame button and turn to pilot flame.

**NOTE :** The light bulb is displayed during light / dimmer setting only. 8 seconds after the light/dimmer has been set, the handset will automatically go into manual mode.

### 5.3.5 Operation of the Fire in “CIRCULATING FAN” mode

- 5.3.5.1 In order to change the mode of operation from “MANUAL” to “CIRCULATING FAN”, briefly press the “SET” button to scroll through to the circulating fan mode as shown below in figure 9, both fan and level icons will flash.

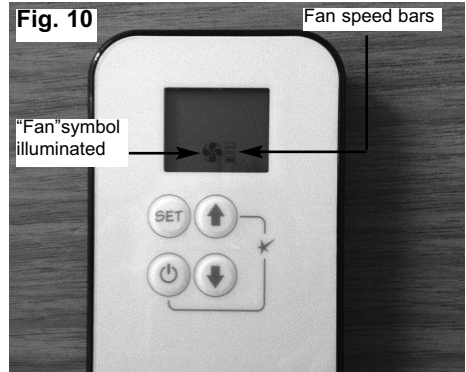
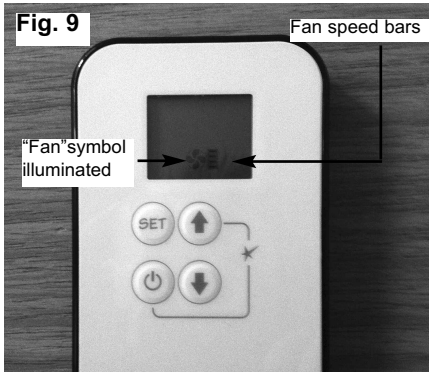

- 5.3.5.2 Press and hold the “LARGE” flame button to turn on the fan and increase fan speed.
- 5.3.5.3 Press and hold the “SMALL” flame button to decrease the fan speed, see figure 9 / 10 for fan speed bar indicator (4 bars illuminated = maximum fan speed, 1 bar illuminated = minimum fan speed).
- 5.3.5.4 To turn the fan off press and hold the “SMALL” flame button until all 4 speed level bars disappear.

**NOTE :** 8 seconds after the light/dimmer has been set, the handset will automatically go into manual mode. The fan starts 4 minutes after the gas supply opens (from OFF or from pilot) at maximum speed and goes to the displayed level after 10 seconds. The fan stops 10 minutes after the gas is off or a pilot only (standby mode).

**IT IS RECOMMENDED FOR MOST EFFICIENT PERFORMANCE OF THE PRODUCT THE FAN MODE IS SET TO THE MAXIMUM (ALL FOUR SPEED BARS) POSITION.**

### 5.3.6 Low Battery Signal

- 5.3.6.1 When the battery in the handset needs replacing, “BATT” will be displayed on the handset.
- 5.3.6.2 Remove the cover on the rear of the handset and replace the 3 off AAA batteries as necessary.

## 5.4 CLEANING - WARNING

Before attempting any cleaning operation ensure that the fire has been allowed to fully cool.

### CLEANING THE ENAMELLED METAL PARTS

These enamelled parts should only be cleaned using a clean, damp cloth. The trim is best cleaned by removing it from the fire and placing it face up on a flat surface. **Abrasive cleaners, chemical cleaning agents or any type of polish must never be used as damage to the finish may result.**

### CLEANING THE FUEL BED

We do not recommend cleaning of logs or fuelbed components as these are fragile and damage may result. **None of these parts must be washed or exposed to any cleaning agents or water.** Any damaged parts must be replaced by contacting your dealer or telephoning BFM Europe on the number stated on the rear cover of this book. Logs or pebbles must only be replaced with a complete and genuine replacement set and the fire must never be run with the wrong number or damaged logs or pebbles. The fuelbed must be carefully re-assembled as stated in the following section.

### CLEANING THE GLASS PANEL

To clean the glass panel, please remove it from the product as described overpage on pages 47-48. Use a clean damp cloth and ceramic glass cleaner to remove any stains or deposits from the glass panel. Do not use scouring pads as this may scratch the surface finish of the glass panel.

**PLEASE NOTE** :- The glass will require cleaning periodically. Condensation produced by the products of combustion will create marks on the inside face of the glass panel.

## 5.5 REMOVING AND REPLACING THE GLASS FRAME & PANEL

- 5.5.1 To remove the glass frame, the glass clamp as supplied in the loose items pack will be required. Secure the clamp to the glass panel as shown below in figure 12.

Fig. 11

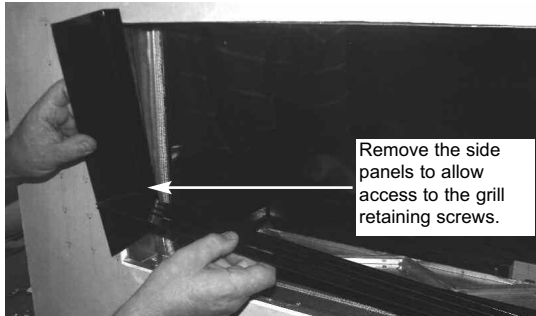

- 5.5.2 Remove the front grill by removing the 2 off retaining screws from the upturned tabs, 1 off at each end of the trim. Remove the side trims by simply lifting clear (they are retained by magnets). See figure 11 above.

Fig. 12

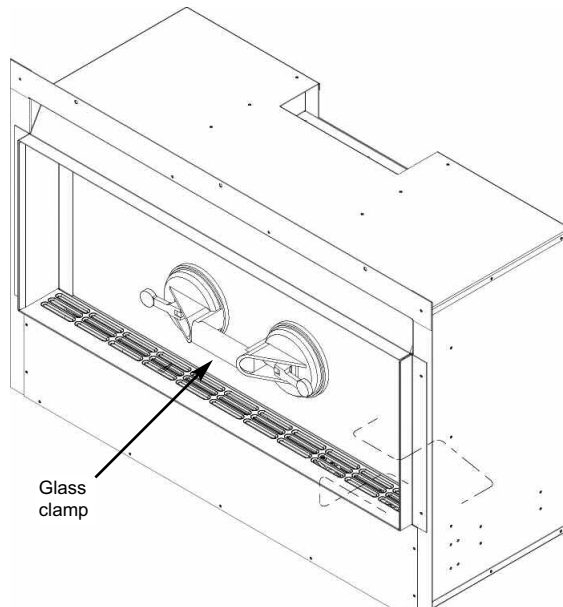

**NOTE :** Always ensure that a consistent seal between the combustion chamber and the glass frame is achieved when replacing the glass panel.



5.5.3 Remove the 5 off securing screws and glass panel retaining bracket that are located on the top underside face of the combustion chamber behind the canopy. See figure 13 below.

**Fig. 13**

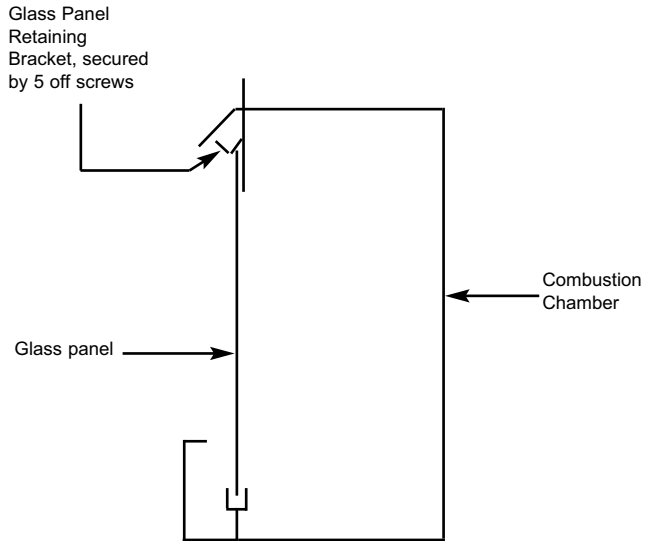

5.5.4 Lift the glass panel vertically to release from the bottom retaining channel and then tilt forwards as shown below in Fig. 14 / 15 to release.

**Fig. 14**

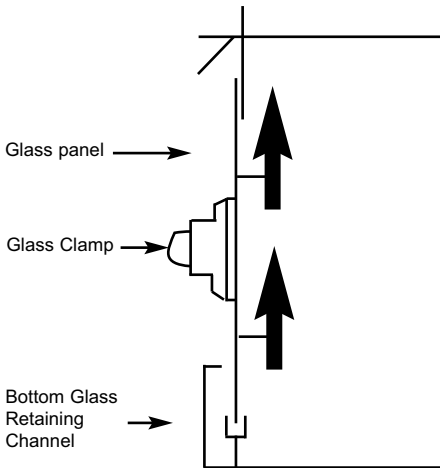

**Fig. 15**

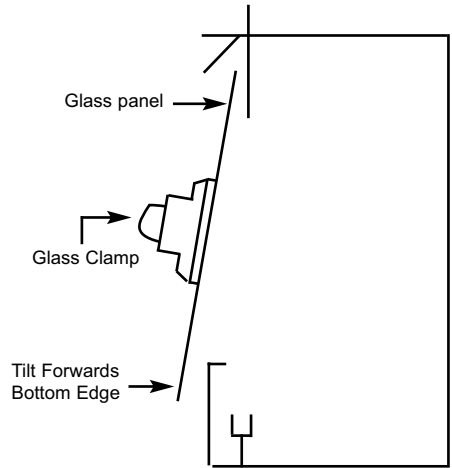

## 5.6 REMOVAL AND REPLACING THE FUEL-BED LOGSET

**IF THE PRODUCT HAS A PEBBLE FUELBED, PLEASE PROCEED TO SECTION 5.7**

**Remove the glass panel as shown on pages 47-48 before attempting to remove or replace the logs.**

5.6.1 The vermiculite material should then be first layed around the burner tray as shown below in figure 16, resulting in an even layer.

**Fig. 16**



5.6.2 Place Log "1" at the left hand side of the burner tray fitting the holes in the bottom face of the log onto the 2 off location pegs as shown below in figure 17.

**Fig. 17**

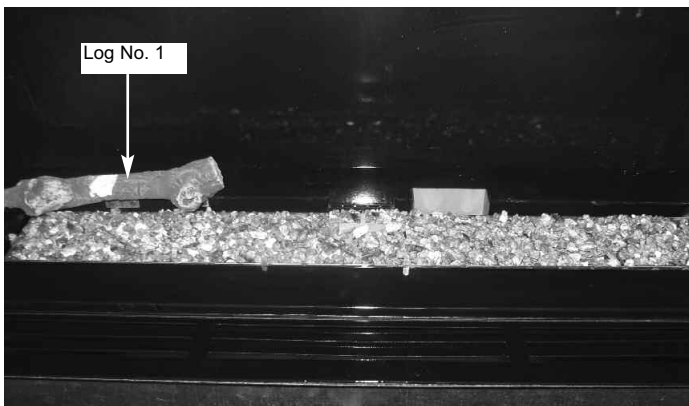

5.6.3 Place Log “2” at the right hand side centre of the burner tray fitting the hole in the bottom face of the log onto the single location peg as shown below in figure 18.

**Fig. 15**

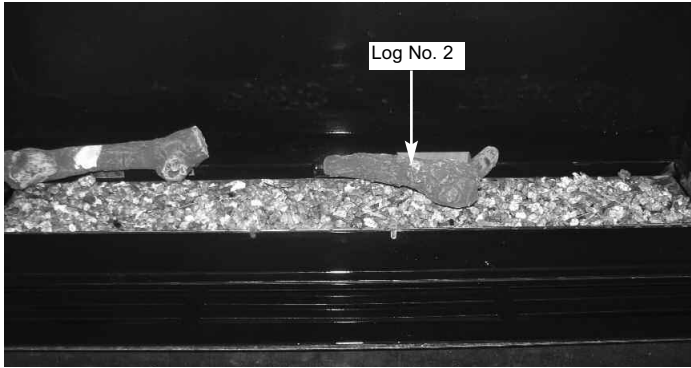

5.6.4 Place Log “3” at the right hand side of the burner tray fitting the hole in the bottom face of the log onto the single location peg as shown below in figure 19.

**Fig. 19**



- 5.6.5 Place Log “4” at the centre of the burner tray fitting the holes in the bottom face of the log onto the 2 off location pegs as shown below in figure 20.

**Fig. 20**

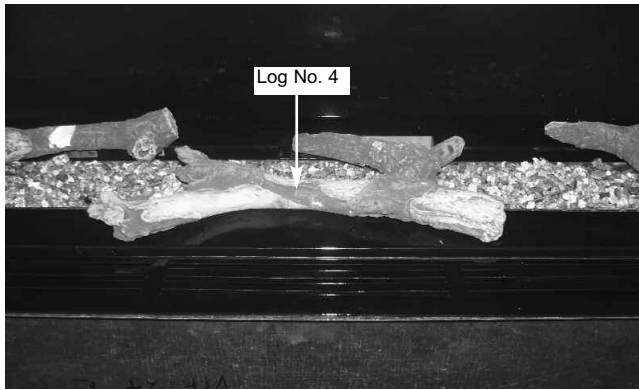

- 5.6.6 Place Log “5” at the right hand side of the burner tray locating in the groove of Log “3” as shown below in figure 21.

**Fig. 21**

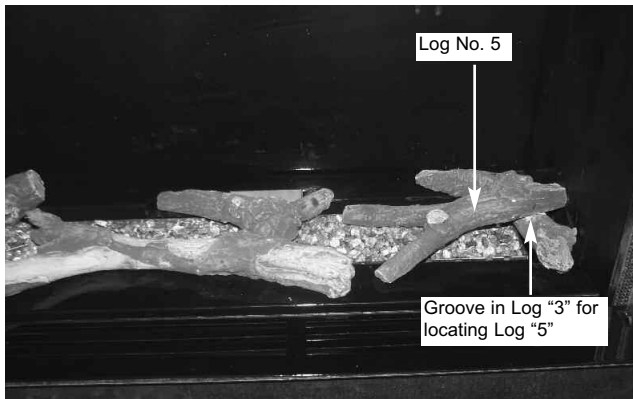

5.6.7 Place Log “6” at the left hand side of the burner tray locating in the groove of Log “1” as shown below in figure 22.

**Fig. 22**

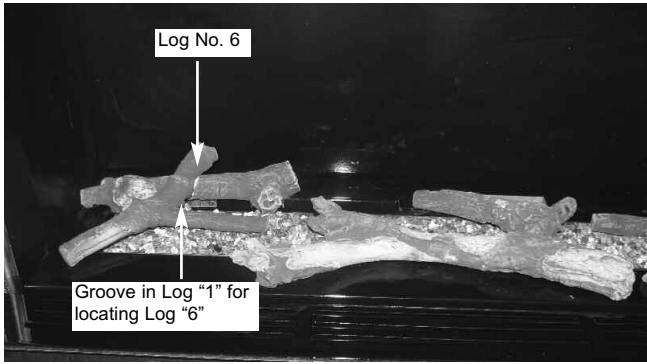

5.6.8 Place Log “7” to the left hand centre side of the burner tray locating on the branch of Log “1” as shown below in figure 23.

**Fig. 23**

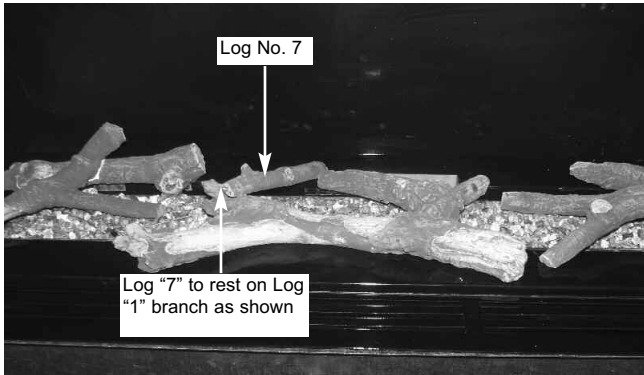

- 5.6.9 If required, fit the embaglow material over the flame ports. To do this, seperate into short strands and place randomly over the flame porting area as shown below in figure 24. **This material is only supplied to improve flame aesthetics and is optional to install.**

**Fig. 24**

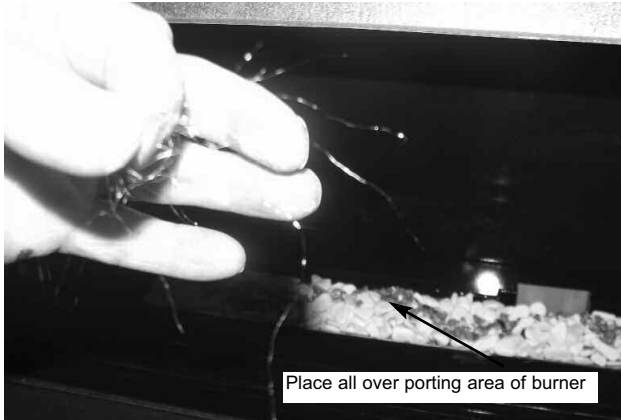

- 5.6.10 Refit the glass panel as described on pages 47-48, then light the appliance as described as in section 5.3

**IMPORTANT NOTE : PLEASE ENSURE THAT WHEN COMMISIONING THE FIRE THE FLAME PATTERN IS EVEN ACROSS THE WIDTH OF THE BURNER. IF AN UNEVEN FLAME PATTERN IS FOUND THEN RELAY THE QUANTITY VERMICULITE TO ACHEIVE AN EVEN FLAME PATTERN.**

**Warning :** Use only the logs supplied with the fire. When replacing the logs remove the old logs and discard them. Fit a complete set of logs of the correct type. Do not fit additional logs or any logs other than a genuine replacement set.

**This appliance does not contain any component manufactured from asbestos or asbestos related products.**

## 5.7 REMOVAL & RE-FITTING THE FUEL-BED PEBBLES

Remove the glass panel as shown on pages 47-48 before attempting to remove or replace the logs.

- 5.7.1 Fit the pebbles to the burner tray as shown below in figure 25, do not fill the flame ports in the burner with pebbles.

Fig. 25

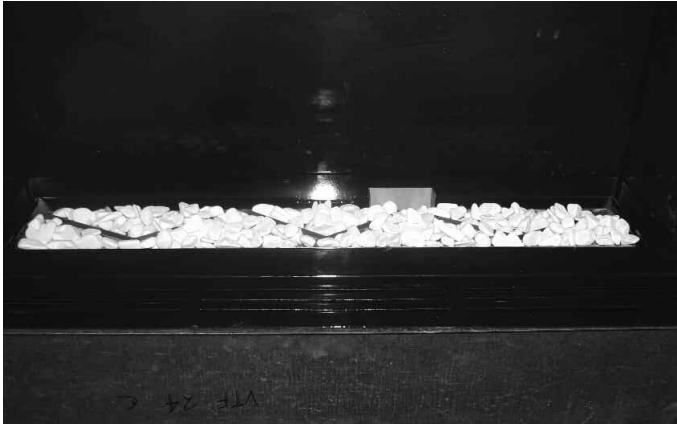

- 5.7.2 Fit the vermiculite material into the burner ports as shown below in figure 26. **This material must be fitted in an even layer to ensure correct operation of the fire.**

Fig. 26



- 5.7.3 If required, fit the embaglow material over the flame ports. To do this, separate into short strands and place randomly over the flame porting area as shown on previous page in figure 24. **This material is only supplied to improve flame aesthetics and is optional to install.**

5.7.4 Refit the glass panel as described on pages 47-48, then light the appliance as described as in section 5.3

## 5.8 User Replaceable Parts

1161-162790	Glass frame assembly
B-128240	Complete log set
B-128250	Log 1 only
B-128260	Log 2 only
B-128270	Log 3 only
B-128280	Log 4 only
B-128290	Log 5 only
B-128300	Log 6 only
B-128310	Log 7 only
B-120070	Glow Fibre
B-128320	Pebble set
CV-107116	Vermiculite

**Due to our policy of continual improvement and development the exact accuracy of illustrations and descriptions contained in this book cannot be guaranteed**

**Part No. B-1001336  
Issue 2**

# THE COLLECTION

by Michael Miller

BFM Europe Ltd.  
Trentham Lakes  
Stoke-on-Trent  
Staffordshire  
ST4 4TJ

[www.bfm-europe.com](http://www.bfm-europe.com)

**Telephone - General Enquiries :**  
**Telephone - Service :**

**(01782) 339000**  
**(01782) 339008**